



FITTING INSTRUCTIONS FOR BCG0005
BRAKE CALIPER GUARD



THIS KIT CONTAINS THE ITEMS PICTURED AND LABELLED OVER PAGE.

SOME PARTS MAY BE SHOWN FOR CLARITY OF INSTRUCTIONS ONLY.

DO NOT PROCEED UNTIL YOU ARE SURE ALL PARTS ARE PRESENT.

PLEASE READ ALL INSTRUCTIONS BEFORE PROCEEDING.

**IF IN ANY DOUBT WHEN FITTING OUR PRODUCTS, CONSULT ONE OF OUR DEALERS
OR HAVE FITTED BY A QUALIFIED TECHNICIAN.**

PLEASE NOTE THAT THE WAY THE KIT IS PACKED DOES NOT NECESSARILY REPRESENT THE WAY OF
MOUNTING TO THE BIKE.

IN THE EVENT OF RUBBER WASHERS BEING USED TO HOLD COMPONENTS ONTO BOLTS,
THESE RUBBER WASHERS CAN BE THROWN AWAY.

DIGITAL COPIES OF THESE INSTRUCTIONS ARE AVAILABLE FROM:

WWW.RG-RACING.COM

R&G Racing
Unit 1, Shelley's Lane, East Worldham, Alton, Hampshire, GU34 3AQ
Tel: +44 (0)1420 89007 Fax: +44 (0)1420 87301 www.rg-racing.com Email: info@rg-racing.com



<u>TOOLS REQUIRED</u>	<u>GENERAL TORQUE SETTINGS</u>
<ul style="list-style-type: none"> • METRIC ALLEN SET • METRIC SOCKET AND WRENCH • TORQUE WRENCH 	<p>M4 BOLT = 8Nm</p> <p>M5 BOLT = 12Nm</p> <p>M6 BOLT = 15Nm</p> <p>M8 BOLT = 20Nm</p> <p>M10 BOLT = 40Nm</p> <p>M12 BOLT = 40Nm</p>

LEGEND

ITEM NO.	DESCRIPTION	QTY
ITEM 1	CAR0029 (CARBON GUARD)	1
ITEM 2	SMW0192 (ALUMINIUM MOUNTING BRACKET)	1
ITEM 3	FS0003BK (100mm STRIP OF SELF-ADHESIVE FOAM)	1
ITEM 4	M4 x 0.70 x 8mm BUTTON HEAD BOLT	2
ITEM 5	M4 x 0.70 HALF NUT	2
ITEM 6	M4 x 8mm OD WASHER	4



ASSEMBLY DIAGRAM

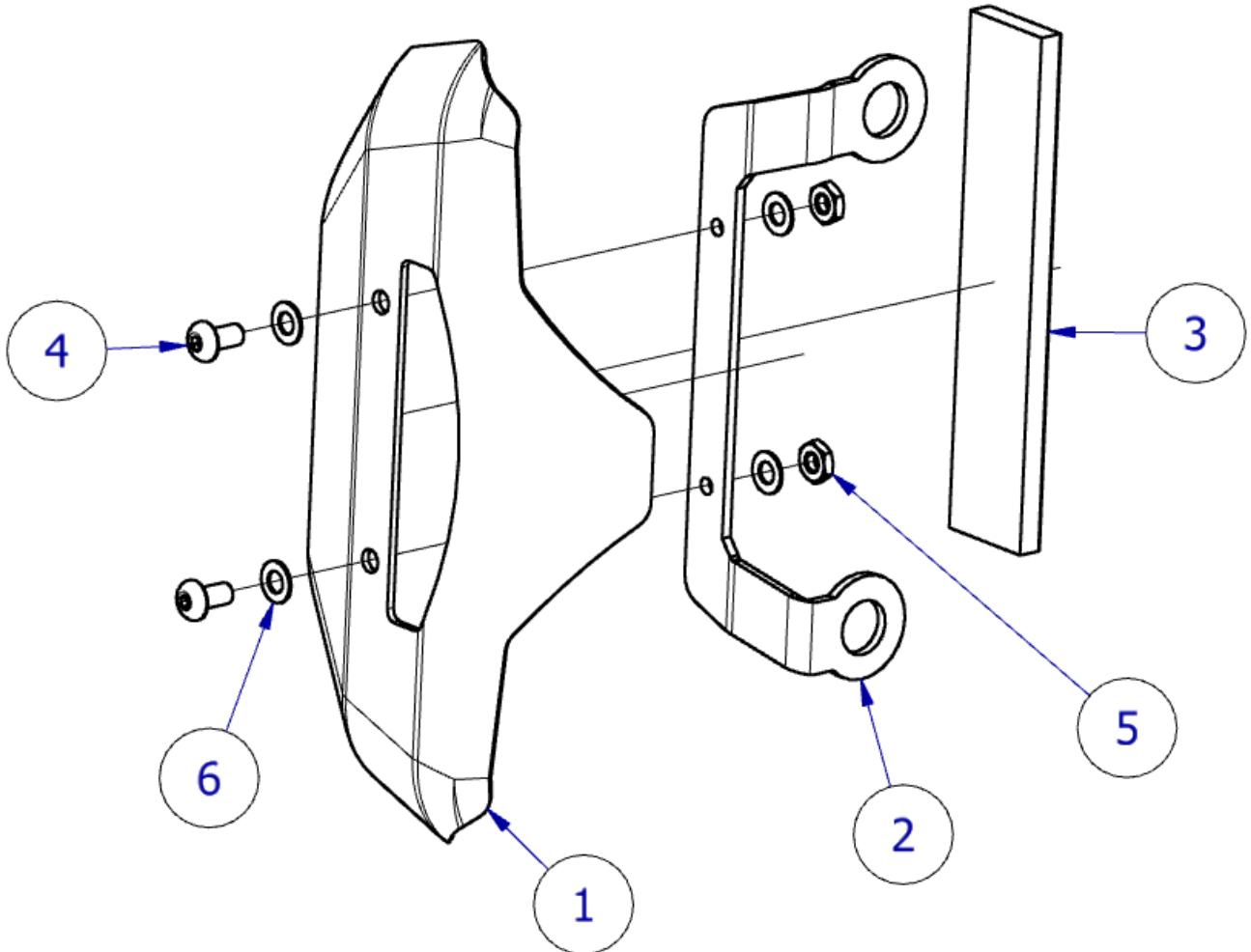

FITTING PICTURES



Picture 1



FITTING INSTRUCTIONS

- Begin by assembling the kit contents as shown in the **ASSEMBLY DIAGRAM**, remembering the self-adhesive foam strip which goes between the brake caliper and the guard.
- Remove your OEM brake caliper mounting bolts as highlighted in **Picture 1**.
- Offer up the carbon caliper guard to your caliper mounting holes and temporarily secure to the fork foot using the OEM brake caliper mounting bolts. Ensuring the bolts go back into the exact same thread they were removed from.
- **REINSTALL** the **CALLIPER MOUNTING BOLTS** to manufacturer's **RECOMMENDED THREAD LOCK AND TORQUE** setting and periodically **RECHECK** they are tight and to the correct torque. If they are not tight, remove, clean and reinstall following manufacturer's recommended thread lock and torque settings.
- Check the front brake is operating correctly before riding the bike, in event of any doubt and you are not comfortable, please have the installation checked or even carried out by a reputable mechanic.

See more R&G products for your Motorcycle in the link below:
[R&G Racing | Cleaning/Lubrication - Gleam range for All Vehicles \(rg-racing.com\)](http://www.rg-racing.com)

ISSUE 1 – 30/03/2023 - (AO)

CONSUMER NOTICE

The catalogue description and any exhibition of samples are only broad indications of the Products and R&G may make design changes which do not diminish their performance or visual appeal and supplying them in such state shall conform to the order. The Buyer acknowledges no representation or warranty (other than as to title) has been given or will apply to the Products other than those in R&G's order or confirmation and the Buyer confirms it has chosen the Products as being of merchantable quality and suitable for its particular purposes. Where R&G fits the Products or undertakes other services it shall exercise reasonable skill and care and rectify any fault free of charge unless the workmanship has been disturbed. The Buyer is responsible for ensuring that the warranty on the motorcycle is not affected by the fitting of the Products. On return of any defective Products R&G shall at its option either supply a replacement or refund the purchase money but shall not be liable if the Products have been modified or used or maintained otherwise than in accordance with R&G's or manufacturer's instructions and good engineering practice or if the defect arises from accident or neglect. Other than identified above and subject to R&G not limiting its liability for causing death and personal injury, it shall not be liable for indirect or consequential loss and otherwise its liability shall be limited to the amounts paid by the Buyer for the Products or the fitting or service concerned. These terms do not affect the Buyer's statutory rights.

R&G RACING RETURNS POLICY (NON-FAULTY GOODS)

Returns must be pre-authorized (if not pre-authorized the return will be rejected). Goods may only be returned direct to us if they were purchased direct from us (customer must prove if necessary). Otherwise to be returned to original vendor. Goods must be in re-sellable condition, in the opinion of R&G Racing. All returns are subject to a 25% restocking and handling fee (25% of the gross value exc. P&P – at the prevailing price at time of purchase). The customer must pay any and all carriage charges. No returns of discontinued products, unless within 14 days of purchase. This policy does not affect your statutory rights and does not refer to faulty goods.

R&G Racing

Unit 1, Shelley's Lane, East Worldham, Alton, Hampshire, GU34 3AQ

Tel: +44 (0)1420 89007 Fax: +44 (0)1420 87301 www.rg-racing.com Email: info@rg-racing.com



NOTICE DE MONTAGE POUR BCG0005
PROTÈGE-ÉTRIER DE FREIN



CE KIT CONTIENT LES ARTICLES ILLUSTRÉS ET ÉTIQUETES SUR LA PAGE.

CERTAINES PARTIES PEUVENT ÊTRE PRÉSENTES UNIQUEMENT POUR LA CLARTE DES INSTRUCTIONS.

NE PAS PROCÉDER AU MONTAGE TANT QUE VOUS N'ÊTES PAS SÛR QUE TOUTES LES PIÈCES SOIENT PRÉSENTES.

VEUILLEZ LIRE TOUTES LES INSTRUCTIONS AVANT DE CONTINUER.

EN CAS DE DOUTE LORS DU MONTAGE DE NOS PRODUITS, CONSULTEZ UN DE NOS REVENEURS OU FAITES APPEL A UN TECHNICIEN QUALIFIÉ.

VEUILLEZ NOTER QUE LA FAÇON DONT LE KIT EST EMBALLÉ NE REPRÉSENTE PAS NECESSAIREMENT LA MANIÈRE DE LE MONTER SUR LA MOTO.

SI DES RONDELLES EN CAOUTCHOUC SONT UTILISÉES POUR MAINTENIR LES COMPOSANTS SUR LES BOULONS, ELLES PEUVENT ÊTRE JETÉES.

NOTICE DISPONIBLE AU TÉLÉCHARGEMENT SUR :

WWW.RG-RACING.COM

R&G Racing

Unit 1, Shelley's Lane, East Worldham, Alton, Hampshire, GU34 3AQ

Tel: +44 (0)1420 89007 Fax: +44 (0)1420 87301 www.rg-racing.com Email: info@rg-racing.com



<u>OUTILS REQUIS</u>	<u>VALEURS DE SERRAGE</u>
<ul style="list-style-type: none"> • CLÉ ALLEN • CLÉ À CLIQUET + DOUILLES • CLÉ DYNAMOMÉTRIQUE 	M4 BOULON = 8Nm M5 BOULON = 12Nm M6 BOULON = 15Nm M8 BOULON = 20Nm M10 BOULON = 40Nm M12 BOULON = 40Nm

LÉGENDE

ARTICLE NO.	DESCRIPTION	QTÉ
ARTICLE 1	CAR0029 (PROTECTION CARBON)	1
ARTICLE 2	SMW0192 (SUPPORT DE FIXATION ALU)	1
ARTICLE 3	FS0003BK (100mm BANDEAU DE MOUSSE ADHÉSIF)	1
ARTICLE 4	M4 x 0.70 x 8mm BOULON	2
ARTICLE 5	M4 x 0.70 DEMI ÉCROU	2
ARTICLE 6	M4 x 8mm RONDELLE	4



SCHÉMA D'ENSEMBLE

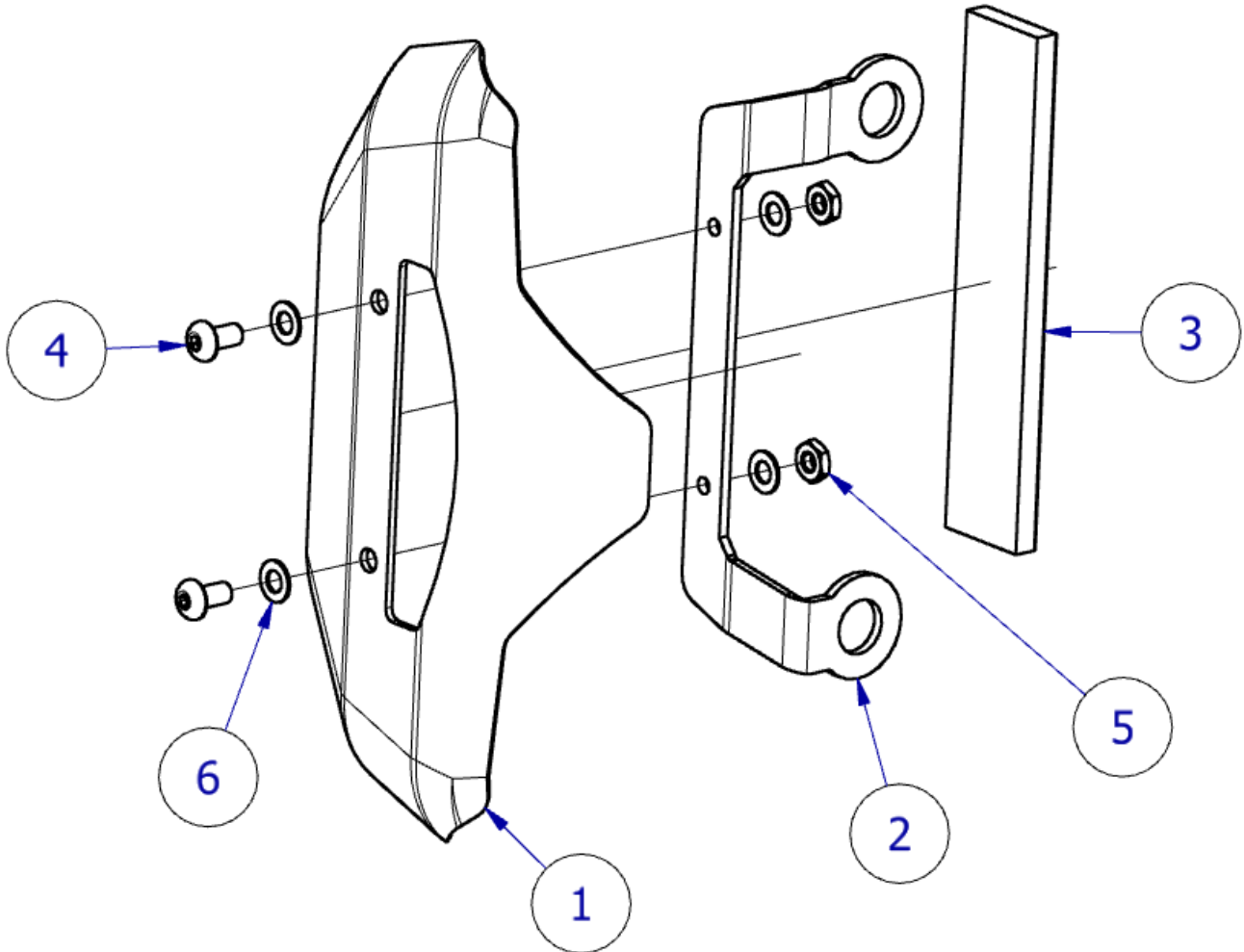

PHOTOS DE MONTAGE



Photo 1



NOTICE DE MONTAGE

- Commencer par assembler le contenu du kit comme indiqué sur le SCHÉMA D'ASSEMBLAGE, en se souvenant de la bande de mousse adhésive qui passe entre l'étrier de frein et la protection.
- Retirez vos boulons de montage d'étrier de frein d'origine comme indiqué sur l'image 1.
- Placez le protège-étrier en carbone sur les trous de montage de votre étrier et fixez-le temporairement au pied de fourche à l'aide des boulons de montage d'étrier de frein d'origine. Assurez-vous que les boulons reviennent exactement dans le même filetage dont ils ont été retirés.
- RÉINSTALLEZ les BOULONS DE MONTAGE DE L'ÉTRIER au réglage FREIN FILET ET COUPLE RECOMMANDÉS par le fabricant et REVÉRIFIEZ périodiquement qu'ils soient serrés et au couple correct. S'ils ne sont pas serrés, retirez, nettoyez et réinstallez en suivant les réglages de frein filet et de couple recommandés par le fabricant.
- Vérifiez que le frein avant fonctionne correctement avant d'utiliser la moto, en cas de doute et si vous n'êtes pas à l'aise, veuillez faire vérifier l'installation ou même l'effectuer par un mécanicien qualifié.

Voir plus de produits R&G pour votre moto via ce lien :
[R&G Racing | Cleaning/Lubrication - Gleam range for All Vehicles \(rg-racing.com\)](http://www.rg-racing.com)

ISSUE 1 – 30/03/2023 - (AO)

CONSUMER NOTICE

The catalogue description and any exhibition of samples are only broad indications of the Products and R&G may make design changes which do not diminish their performance or visual appeal and supplying them in such state shall conform to the order. The Buyer acknowledges no representation or warranty (other than as to title) has been given or will apply to the Products other than those in R&G's order or confirmation and the Buyer confirms it has chosen the Products as being of merchantable quality and suitable for its particular purposes. Where R&G fits the Products or undertakes other services it shall exercise reasonable skill and care and rectify any fault free of charge unless the workmanship has been disturbed. The Buyer is responsible for ensuring that the warranty on the motorcycle is not affected by the fitting of the Products. On return of any defective Products R&G shall at its option either supply a replacement or refund the purchase money but shall not be liable if the Products have been modified or used or maintained otherwise than in accordance with R&G's or manufacturer's instructions and good engineering practice or if the defect arises from accident or neglect. Other than identified above and subject to R&G not limiting its liability for causing death and personal injury, it shall not be liable for indirect or consequential loss and otherwise its liability shall be limited to the amounts paid by the Buyer for the Products or the fitting or service concerned. These terms do not affect the Buyer's statutory rights.

R&G RACING RETURNS POLICY (NON-FAULTY GOODS)

Returns must be pre-authorized (if not pre-authorized the return will be rejected). Goods may only be returned direct to us if they were purchased direct from us (customer must prove if necessary). Otherwise to be returned to original vendor. Goods must be in re-sellable condition, in the opinion of R&G Racing. All returns are subject to a 25% restocking and handling fee (25% of the gross value exc. P&P – at the prevailing price at time of purchase). The customer must pay any and all carriage charges. No returns of discontinued products, unless within 14 days of purchase. This policy does not affect your statutory rights and does not refer to faulty goods.

R&G Racing

Unit 1, Shelley's Lane, East Worldham, Alton, Hampshire, GU34 3AQ

Tel: +44 (0)1420 89007 Fax: +44 (0)1420 87301 www.rg-racing.com Email: info@rg-racing.com