



FITTING INSTRUCTIONS FOR CP0565 CRASH PROTECTORS



PICTURE A

PICTURE B

THIS KIT CONTAINS THE ITEMS PICTURED AND LABELLED OVER PAGE.

SOME PARTS MAY BE SHOWN FOR CLARITY OF INSTRUCTIONS ONLY.

DO NOT PROCEED UNTIL YOU ARE SURE ALL PARTS ARE PRESENT.

PLEASE READ ALL INSTRUCTIONS BEFORE PROCEEDING.

**IF IN ANY DOUBT WHEN FITTING OUR PRODUCTS, CONSULT ONE OF OUR DEALERS
OR HAVE FITTED BY A QUALIFIED TECHNICIAN.**

PLEASE NOTE THAT THE WAY THE KIT IS PACKED DOES NOT NECESSARILY REPRESENT THE WAY OF
MOUNTING TO THE BIKE.

IN THE EVENT OF RUBBER WASHERS BEING USED TO HOLD COMPONENTS ONTO BOLTS,

THESE RUBBER WASHERS CAN BE THROWN AWAY.

DIGITAL COPIES OF THESE INSTRUCTIONS ARE AVAILABLE FROM:

WWW.RG-RACING.COM

R&G Racing

Unit 1, Shelley's Lane, East Worldham, Alton, Hampshire, GU34 3AQ

Tel: +44 (0)1420 89007 Fax: +44 (0)1420 87301 www.rg-racing.com Email: info@rg-racing.com



<u>TOOLS REQUIRED</u>	<u>GENERAL TORQUE SETTINGS</u>
<ul style="list-style-type: none"> • Socket set • Ratchet • Torque wrench (up to 50Nm). 	M4 BOLT = 8Nm M5 BOLT = 12Nm M6 BOLT = 15Nm M8 BOLT = 20Nm M10 BOLT = 40Nm M12 BOLT = 40Nm

LEGEND

ITEM NO.	DESCRIPTION	QTY
ITEM 1	CRASH BOBBIN (BO431 WITH CS341/S0255)	2
ITEM 2	M0794 (MOUNTING BRACKET RHS)	1
ITEM 3	M0795 (MOUNTING BRACKET LHS)	1
ITEM 4	S1488 SPACER INNER BELLY PAN BOTH SIDES	2
ITEM 5	S1489 SPACER OUTER BELLY PAN LHS	1
ITEM 6	S1490 SPACER OUTER BELLY PAN RHS	1
ITEM 7	S1491 SPACER REAR RHS	1
ITEM 8	S1492 SPACER REAR LHS	1
ITEM 9	S1493 SPACER CRASH BOBBIN	2
ITEM 10	M8x1.25x80mm CAP HEAD BOLT	1
ITEM 11	M10x1.50x75mm CAP HEAD BOLT	1
ITEM 12	M10x1.50x80mm HEX HEAD BOLT	2
ITEM 13	M12x1.25x65mm HEX HEAD BOLT	1
ITEM 14	M12x1.25x80mm HEX HEAD BOLT	1
ITEM 15	M10x19mm FLAT WASHER	2
ITEM 16	M12x19mm FLAT WASHER	2
ITEM 17	LW0001 SHAKE PROOF WASHER	2
ITEM 18	NC0002 NUT CAP M12	2
ITEM 19	NC0009 NUT CAP M8	2
ITEM 20	NC0010 NUT CAP M10	2
ITEM 21	BC0002 BOBBIN CAP	2

R&G Racing

Unit 1, Shelley's Lane, East Worldham, Alton, Hampshire, GU34 3AQ

Tel: +44 (0)1420 89007 Fax: +44 (0)1420 87301 www.rg-racing.com Email: info@rg-racing.com



EXPLODED ASSEMBLY VIEW

RHS

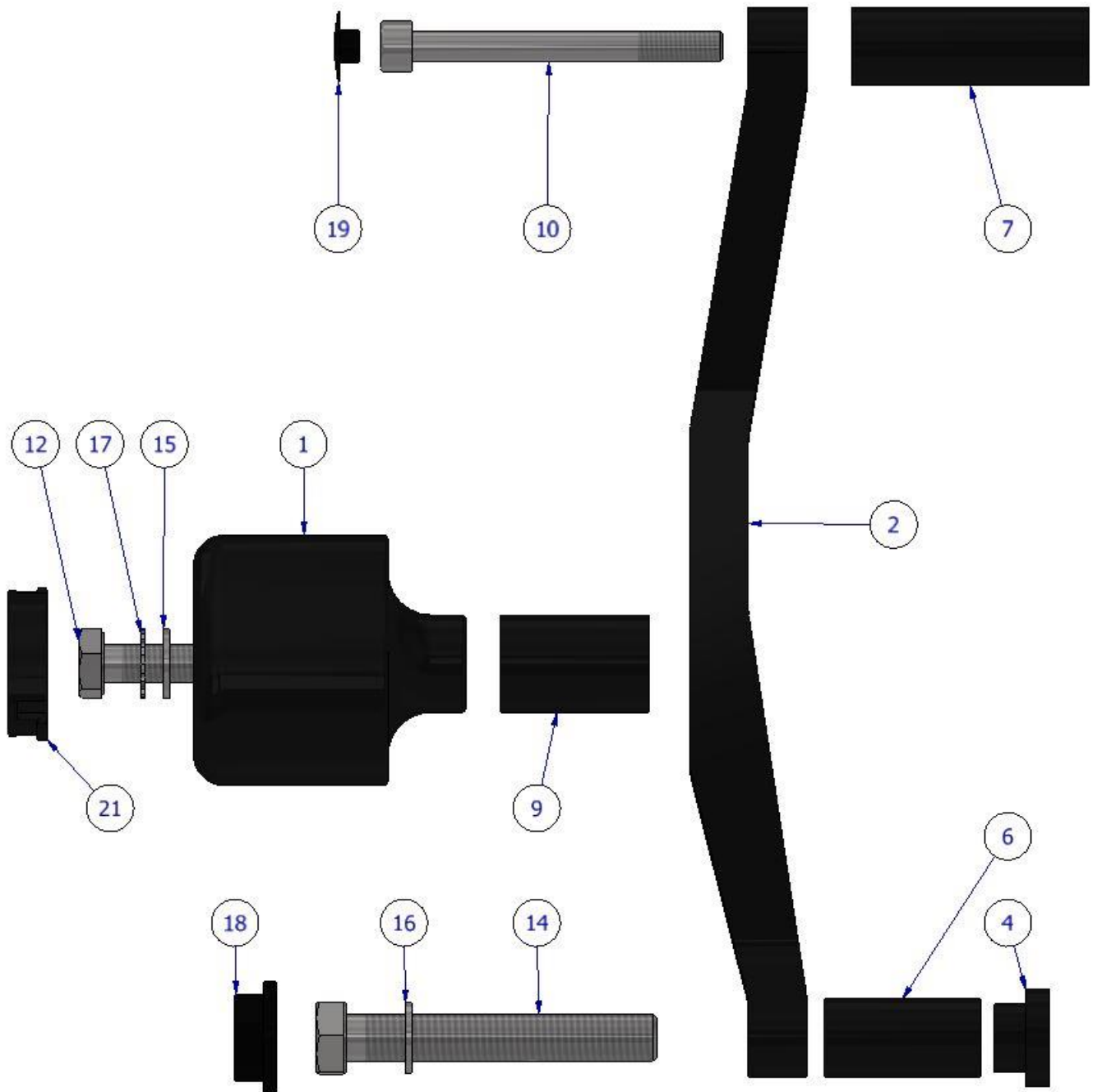



LHS

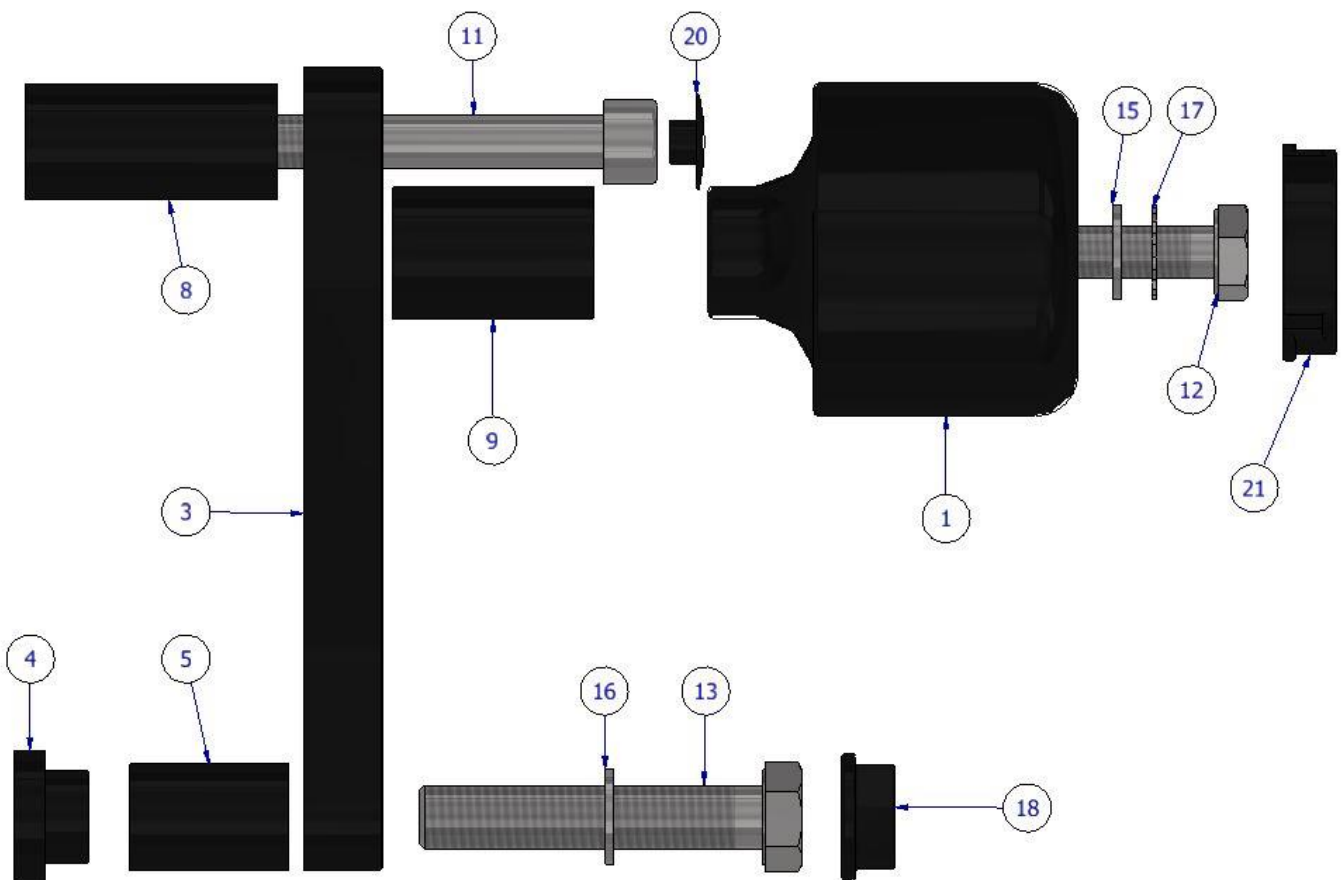

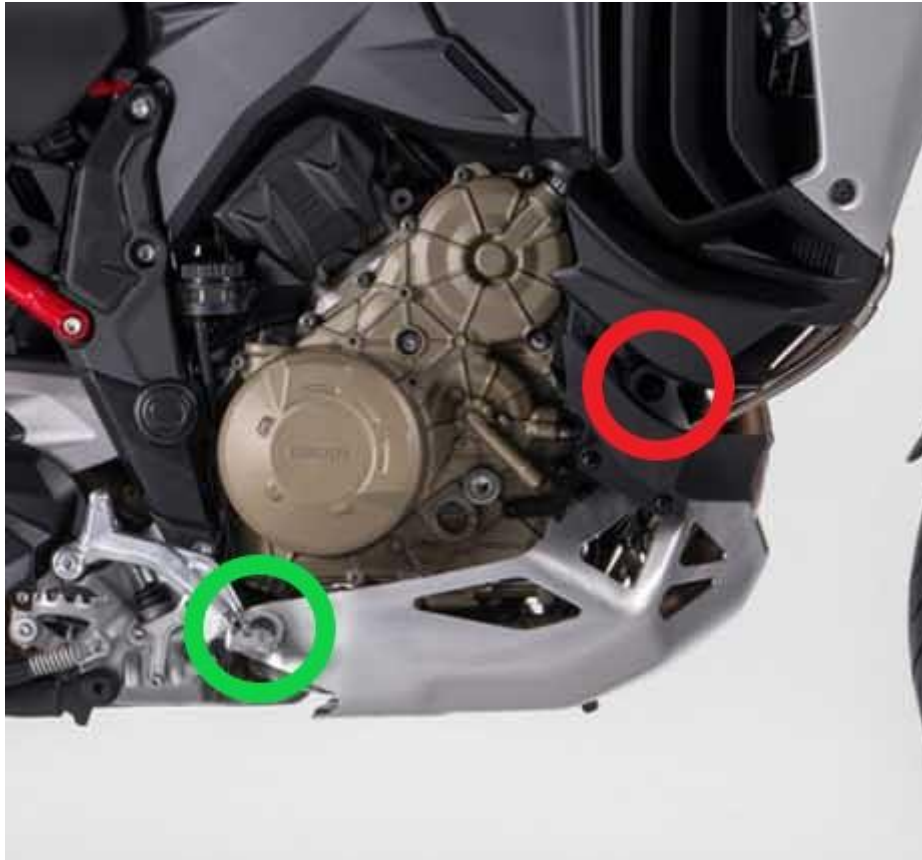
**PICTURE C****FITTING INSTRUCTIONS**

Before removing engine bolts, ensure the bike is upright and supported by a suitable engine stand or jack placed under the sump of the motorbike to support the partial weight of the engine, this will prevent the engine from moving during fitting. DO NOT REMOVE MORE THAN 1 ENGINE BOLT AT ANY TIME.

1. Remove the bolts from the OEM belly pan as located in **PICTURE C** on page 5. This is the same on both sides of the bike.
2. Once the belly pan is off the bike, remove the threaded inserts on both sides located in the red circle in **PICTURE C**.
3. Assemble the crash protector kit as shown in the **EXPLODED ASSEMBLY VIEW** for both RHS & LHS but at this stage leave the spacer inner belly pan **ITEM 4** out of both assemblies.
4. Place the inner belly pan spacer through the inside of the belly pan in the location of the red circle in **PICTURE C** and then mount the belly pan back onto the bike but only the lower rear bolt located in the green circle in **PICTURE C** as this allows you to have more control when mounting the full assembly.



5. Offer the RHS assembly into position as shown in **picture A** on page 1. Ensure the front M12 bolt is inserted through the belly pan and spacer ITEM 4. Finally tighten the bolts until you feel some compression. Using our GENERAL TORQUE SETTINGS on PAGE 2 tighten all bolts to the correct torque. **PLEASE NOTE THE CRASH PROTECTOR MUST BE POSITIONED AS SHOWN IN THE PICTURES WITH BIGGER END TOWARD FRONT OF BIKE.**
6. If not already fitted, fit bubble sticker into recess of bobbin cap (**ITEM 21**).
7. Fit crash protector cap (**ITEM 21**) into the crash protector (**ITEM 1**).

REPEAT THE ABOVE STEPS FOR BOTH SIDES OF THE MOTORCYCLE.

See more R&G products for your Motorcycle On:

ISSUE 1 - 19/12/2023 (JH)

CONSUMER NOTICE

The catalogue description and any exhibition of samples are only broad indications of the Products and R&G may make design changes which do not diminish their performance or visual appeal and supplying them in such state shall conform to the order. The Buyer acknowledges no representation or warranty (other than as to title) has been given or will apply to the Products other than those in R&G's order or confirmation and the Buyer confirms it has chosen the Products as being of merchantable quality and suitable for its particular purposes. Where R&G fits the Products or undertakes other services it shall exercise reasonable skill and care and rectify any fault free of charge unless the workmanship has been disturbed. The Buyer is responsible for ensuring that the warranty on the motorcycle is not affected by the fitting of the Products. On return of any defective Products R&G shall at its option either supply a replacement or refund the purchase money but shall not be liable if the Products have been modified or used or maintained otherwise than in accordance with R&G's or manufacturer's instructions and good engineering practice or if the defect arises from accident or neglect. Other than identified above and subject to R&G not limiting its liability for causing death and personal injury, it shall not be liable for indirect or consequential loss and otherwise its liability shall be limited to the amounts paid by the Buyer for the Products or the fitting or service concerned. These terms do not affect the Buyer's statutory rights.

R&G RACING RETURNS POLICY (NON-FAULTY GOODS)

Returns must be pre-authorized (if not pre-authorized the return will be rejected). Goods may only be returned direct to us if they were purchased direct from us (customer must prove if necessary). Otherwise to be returned to original vendor. Goods must be in re-sellable condition, in the opinion of R&G Racing. All returns are subject to a 25% restocking and handling fee (25% of the gross value exc. P&P – at the prevailing price at time of purchase). The customer must pay any and all carriage charges. No returns of discontinued products, unless within 14 days of purchase. This policy does not affect your statutory rights and does not refer to faulty goods.

R&G Racing

Unit 1, Shelley's Lane, East Worldham, Alton, Hampshire, GU34 3AQ

Tel: +44 (0)1420 89007 Fax: +44 (0)1420 87301 www.rg-racing.com Email: info@rg-racing.com



NOTICE DE MONTAGE POUR CP0565 PROTECTIONS CRASH



PHOTO A



PHOTO B

CE KIT CONTIENT LES ARTICLES ILLUSTRÉS ET ÉTIQUETES SUR LA PAGE.

CERTAINES PARTIES PEUVENT ÊTRE PRÉSENTES UNIQUEMENT POUR LA CLARTÉ DES INSTRUCTIONS.

NE PAS PROCÉDER AU MONTAGE TANT QUE VOUS N'ÊTES PAS SÛR QUE TOUTES LES PIÈCES SOIENT PRÉSENTES.

VEUILLEZ LIRE TOUTES LES INSTRUCTIONS AVANT DE CONTINUER.

EN CAS DE DOUTE LORS DU MONTAGE DE NOS PRODUITS, CONSULTEZ UN DE NOS REVENDEURS OU FAITES APPEL À UN TECHNICIEN QUALIFIÉ.

VEUILLEZ NOTER QUE LA FAÇON DONT LE KIT EST EMBALLÉ NE REPRÉSENTE PAS NECESSAIREMENT LA MANIÈRE DE LE MONTER SUR LA MOTO.

SI DES RONDELLES EN CAOUTCHOUC SONT UTILISÉES POUR MAINTENIR LES COMPOSANTS SUR LES BOULONS, ELLES PEUVENT ÊTRE JETÉES.

NOTICE DISPONIBLE AU TÉLÉCHARGEMENT SUR :

WWW.RG-RACING.COM

R&G Racing

Unit 1, Shelley's Lane, East Worldham, Alton, Hampshire, GU34 3AQ

Tel: +44 (0)1420 89007 Fax: +44 (0)1420 87301 www.rg-racing.com Email: info@rg-racing.com



<u>OUTILS REQUIS</u>	<u>VALEURS DE SERRAGE</u>
<ul style="list-style-type: none"> • Clé à cliquet • Cliquet • Clé dynamométrique (jusqu'à 50Nm). 	M4 BOULON = 8Nm M5 BOULON = 12Nm M6 BOULON = 15Nm M8 BOULON = 20Nm M10 BOULON = 40Nm M12 BOULON = 40Nm

LÉGENDE

ARTICLE NO.	DESCRIPTION	QTÉ
ARTICLE 1	PROTECTION CRASH (BO431 AVEC CS341/S0255)	2
ARTICLE 2	M0794 (SUPPORT MONTAGE CÔTÉ DROIT)	1
ARTICLE 3	M0795 (SUPPORT MONTAGE CÔTÉ GAUCHE)	1
ARTICLE 4	S1488 ENTRETOISE SABOT MOTEUR DES DEUX CÔTÉS	2
ARTICLE 5	S1489 ENTRETOISE EXTÉRIEURE DE SABOT MOTEUR CÔTÉ GAUCHE	1
ARTICLE 6	S1490 ENTRETOISE EXTÉRIEURE DE SABOT MOTEUR CÔTÉ DROIT	1
ARTICLE 7	S1491 ENTRETOISE ARRIÈRE DROITE	1
ARTICLE 8	S1492 ENTRETOISE ARRIÈRE GAUCHE	1
ARTICLE 9	S1493 ENTRETOISE DE PROTECTION CRASH	2
ARTICLE 10	M8x1.25x80mm BOULON	1
ARTICLE 11	M10x1.50x75mm BOULON	1
ARTICLE 12	M10x1.50x80mm BOULON	2
ARTICLE 13	M12x1.25x65mm BOULON	1
ARTICLE 14	M12x1.25x80mm BOULON	1
ARTICLE 15	M10x19mm RONDELLE	2
ARTICLE 16	M12x19mm RONDELLE	2
ARTICLE 17	LW0001 RONDELLE ANTI VIBRATION	2
ARTICLE 18	NC0002 ÉCROU M12	2
ARTICLE 19	NC0009 ÉCROU M8	2
ARTICLE 20	NC0010 ÉCROU M10	2
ARTICLE 21	BC0002 CAPUCHON DE PROTECTION	2

R&G Racing

Unit 1, Shelley's Lane, East Worldham, Alton, Hampshire, GU34 3AQ

Tel: +44 (0)1420 89007 Fax: +44 (0)1420 87301 www.rg-racing.com Email: info@rg-racing.com



VUE D'ENSEMBLE

CÔTÉ DROIT

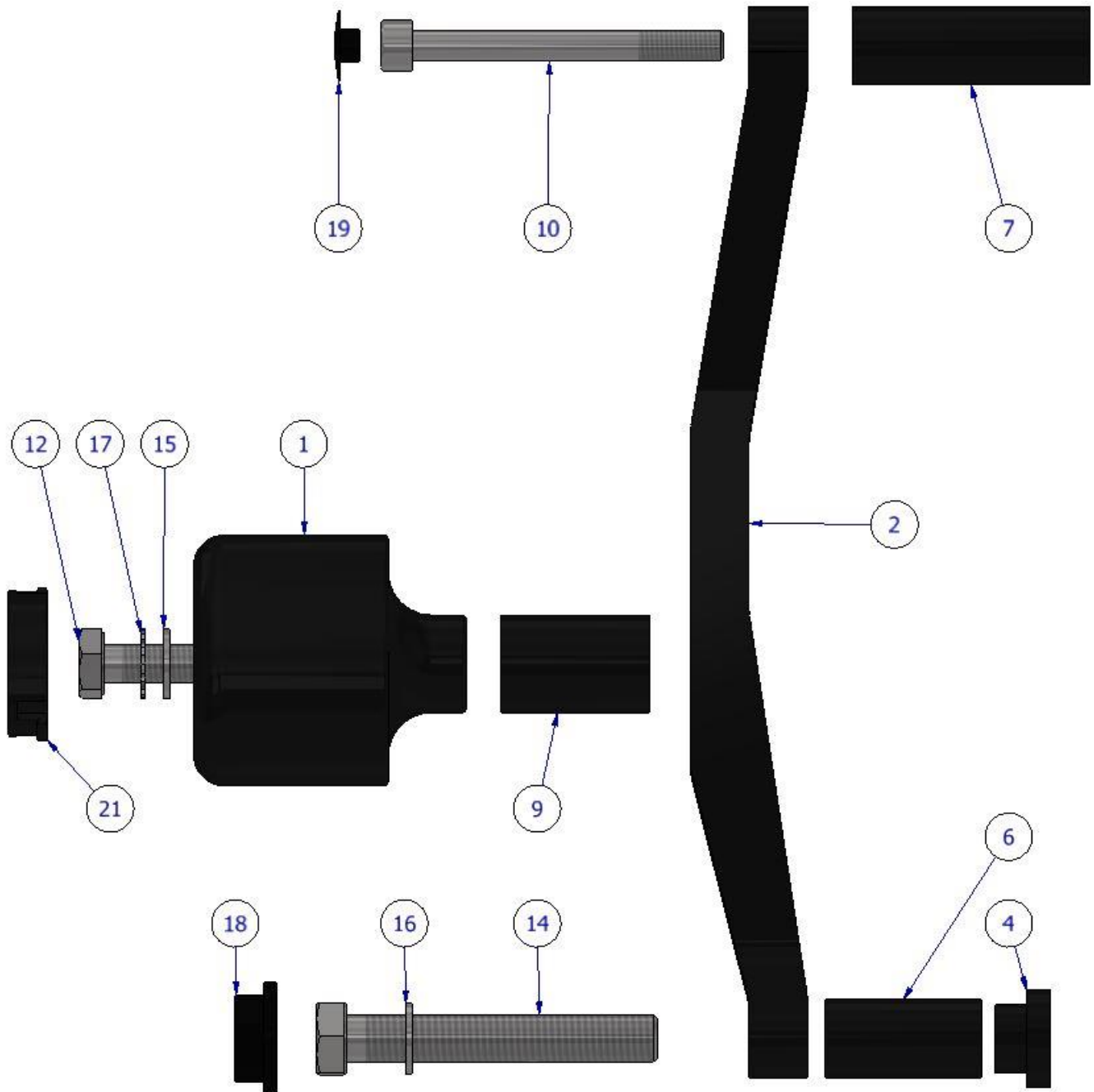



CÔTÉ GAUCHE

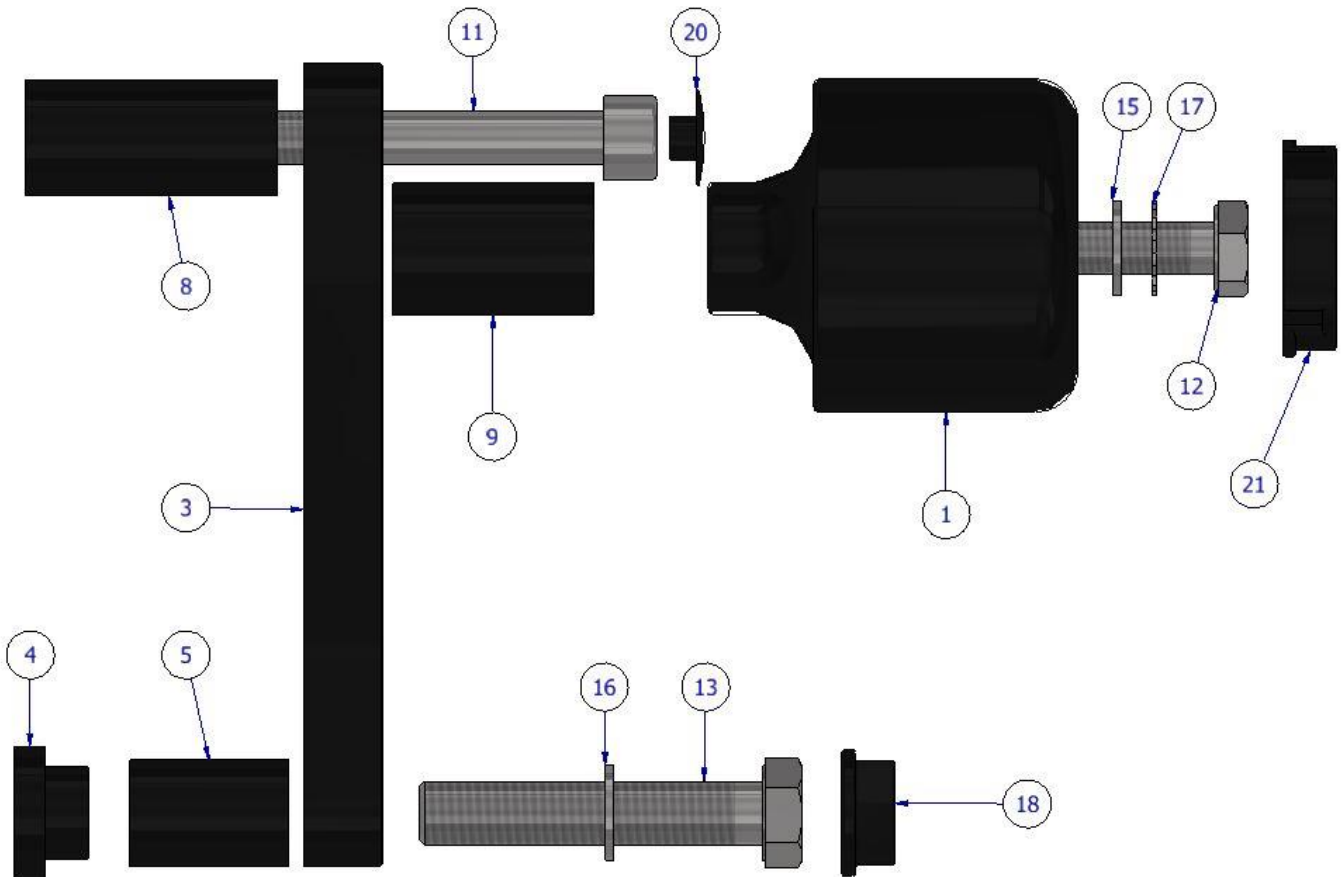

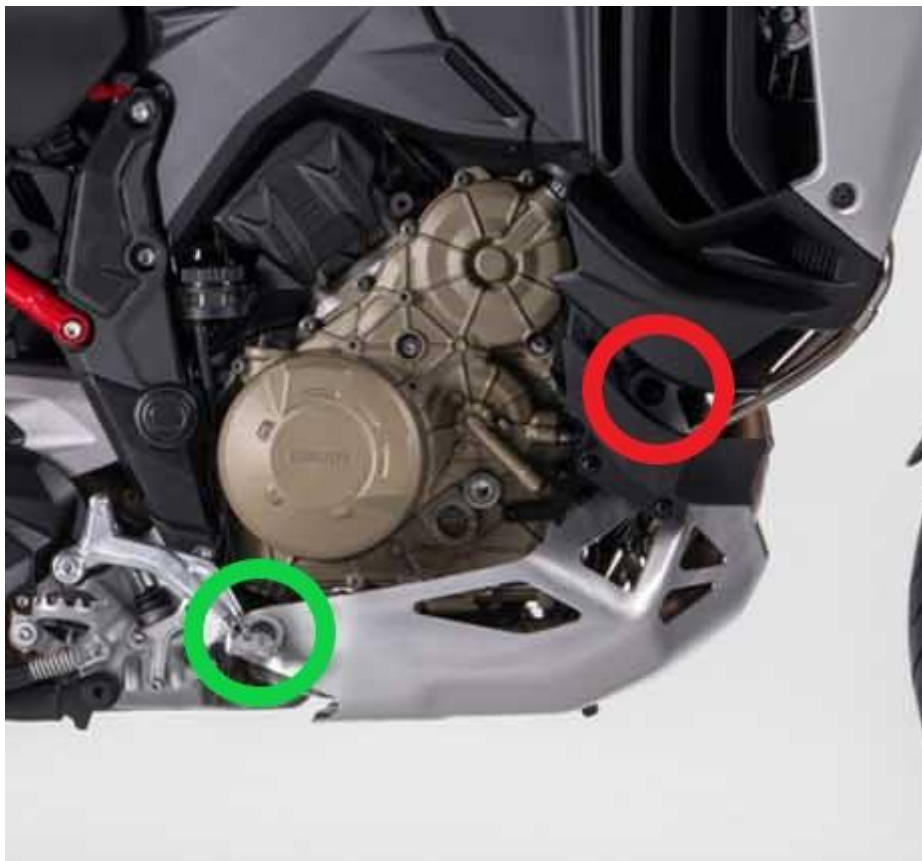

PHOTO C

NOTICE DE MONTAGE

Avant de retirer les boulons du moteur, assurez-vous que la moto soit droite et soutenue par un support moteur ou un cric approprié placé sous le carter de la moto pour supporter une partie du poids du moteur, cela évitera que le moteur bouge pendant le montage. **NE PAS RETIRER PLUS D'UN BOULON DE MOTEUR À LA FOIS.**

1. Retirez les boulons du carter moteur d'origine comme indiqué sur la PHOTO C à la page 5. C'est la même chose des deux côtés de la moto
2. Une fois le sabot moteur retiré de la moto, retirez les inserts filetés des deux côtés situés dans le cercle rouge sur la PHOTO C.
3. Assemblez le kit de protection crash comme indiqué sur la VUE D'ENSEMBLE du côté droit et gauche mais à ce stade, laissez l'entretoise de sabot moteur intérieur ARTICLE 4 en dehors des deux assemblages.
4. Placez l'entretoise intérieure du sabot moteur à travers l'intérieur du sabot moteur à l'emplacement du cercle rouge sur la PHOTO C, puis remontez le sabot moteur sur la moto mais

R&G Racing

Unit 1, Shelley's Lane, East Worldham, Alton, Hampshire, GU34 3AQ

Tel: +44 (0)1420 89007 Fax: +44 (0)1420 87301 www.rg-racing.com Email: info@rg-racing.com



uniquement le boulon arrière inférieur situé dans le cercle vert sur la PHOTO C car cela vous permet d'avoir plus de contrôle lors du montage de l'ensemble complet.

5. Présentez l'ensemble côté droit en position comme indiqué sur la photo A à la page 1. Assurez-vous que le boulon avant M12 soit inséré à travers le carter moteur et l'entretoise ARTICLE 4. Enfin, serrez les boulons jusqu'à ce que vous sentiez une certaine compression. À l'aide de nos RÉGLAGES GÉNÉRAUX DE COUPLE à la PAGE 2, serrez tous les boulons au couple correct.

VEUILLEZ NOTER QUE LA PROTECTION CRASH DOIT ÊTRE POSITIONNÉE COMME INDIQUÉ SUR LES PHOTOS AVEC LA PLUS GRANDE EXTRÉMITÉ VERS L'AVANT DE LA MOTO.

6. S'il n'est pas déjà installé, placez le sticker à bulles dans le creux du capuchon de la protection (ARTICLE 21).
7. Installez le capuchon de protection crash (ARTICLE 21) dans la protection crash (ARTICLE 1).

RÉPÉTEZ LES ÉTAPES CI-DESSUS DES DEUX CÔTÉS DE LA MOTO.

Voir plus de produits R&G pour votre moto :

ISSUE 1 - 19/12/2023 (JH)

CONSUMER NOTICE

The catalogue description and any exhibition of samples are only broad indications of the Products and R&G may make design changes which do not diminish their performance or visual appeal and supplying them in such state shall conform to the order. The Buyer acknowledges no representation or warranty (other than as to title) has been given or will apply to the Products other than those in R&G's order or confirmation and the Buyer confirms it has chosen the Products as being of merchantable quality and suitable for its particular purposes. Where R&G fits the Products or undertakes other services it shall exercise reasonable skill and care and rectify any fault free of charge unless the workmanship has been disturbed. The Buyer is responsible for ensuring that the warranty on the motorcycle is not affected by the fitting of the Products. On return of any defective Products R&G shall at its option either supply a replacement or refund the purchase money but shall not be liable if the Products have been modified or used or maintained otherwise than in accordance with R&G's or manufacturer's instructions and good engineering practice or if the defect arises from accident or neglect. Other than identified above and subject to R&G not limiting its liability for causing death and personal injury, it shall not be liable for indirect or consequential loss and otherwise its liability shall be limited to the amounts paid by the Buyer for the Products or the fitting or service concerned. These terms do not affect the Buyer's statutory rights.

R&G RACING RETURNS POLICY (NON-FAULTY GOODS)

Returns must be pre-authorized (if not pre-authorized the return will be rejected). Goods may only be returned direct to us if they were purchased direct from us (customer must prove if necessary). Otherwise to be returned to original vendor. Goods must be in re-sellable condition, in the opinion of R&G Racing. All returns are subject to a 25% restocking and handling fee (25% of the gross value exc. P&P – at the prevailing price at time of purchase). The customer must pay any and all carriage charges. No returns of discontinued products, unless within 14 days of purchase. This policy does not affect your statutory rights and does not refer to faulty goods.

R&G Racing

Unit 1, Shelley's Lane, East Worldham, Alton, Hampshire, GU34 3AQ

Tel: +44 (0)1420 89007 Fax: +44 (0)1420 87301 www.rg-racing.com Email: info@rg-racing.com