

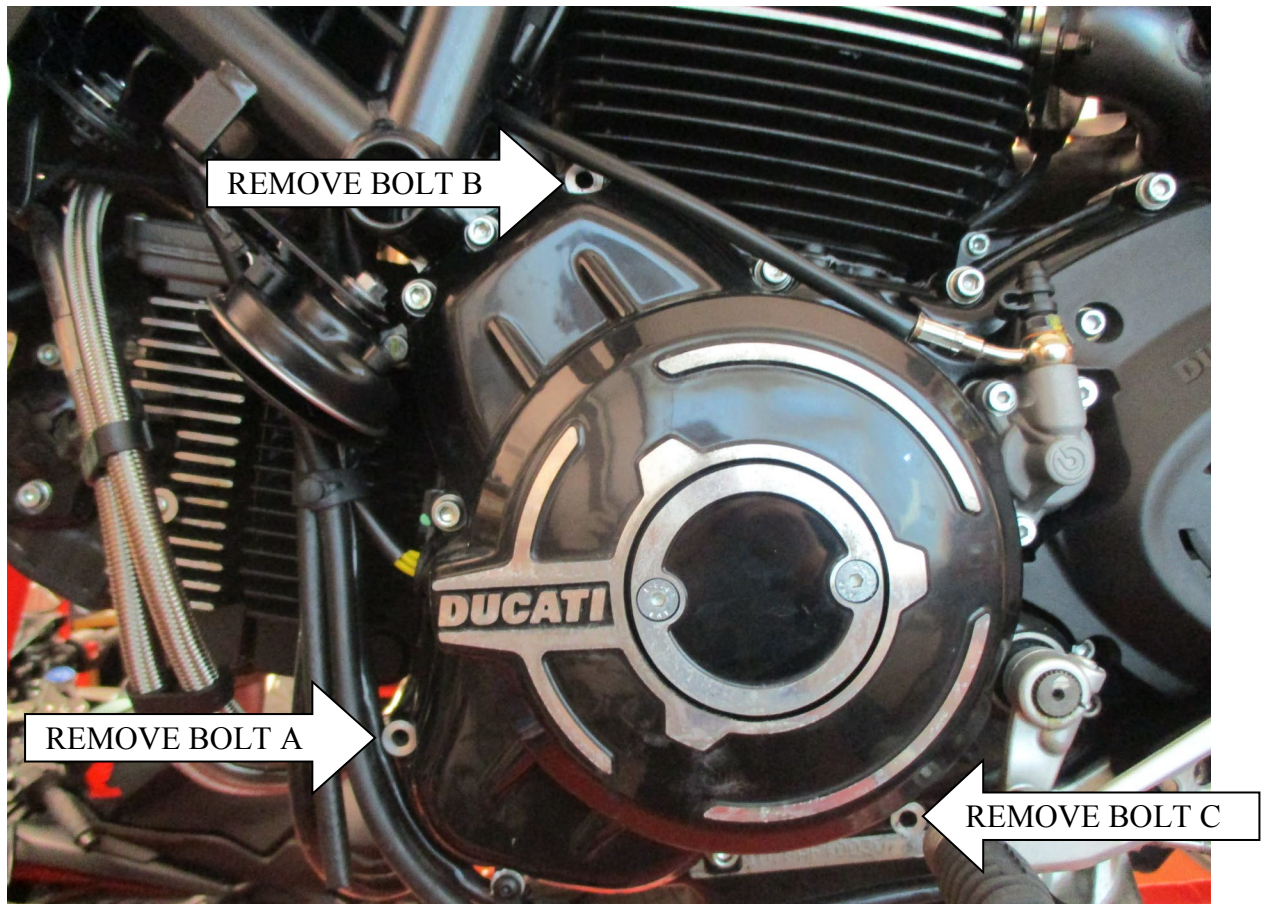

FITTING INSTRUCTIONS FOR ECC0272 DUCATI SCRABLER 1100 2018- LHS ENGINE CASE COVER



This Kit Contains:

- 1x ENGINE CASE COVER (ECC0272)
- 2 x M6 x 40mm LONG CAP HEAD BOLTS
- 1 x M6 x 45mm LONG CAP HEAD BOLT
- 3 x THREADED COLLAR (S1123)
- 1 x 360° TOP HAT SPACER (S1124)
- 1 x 90° TOP HAT SPACER (S1126)
- 1 x 60° TOP HAT SPACER (S1127)

Digital copies of these instructions are available to download from www.rg-racing.com



PLEASE READ THESE INSTRUCTIONS FULLY BEFORE STARTING

- Please make sure the engine is cold before proceeding with the fitting of the R&G cover.
- To fit the R&G engine case cover remove the three M6 engine case bolts in the positions arrowed above. Hold the cover loosely over the case to help identify the correct ones. **DO NOT REMOVE ALL OF THE CASE BOLTS.**
- Fit the three different top hat spacers into the three holes of the engine case cover, as shown in the diagram below. Ensure they are correctly seated before proceeding, and secure in place using the threaded collars. **NOTE: Do not over tighten the collars, as the bolts need to be free to locate with the holes in the engine casing.**

SPACER POSITIONS

BOLT A - 90° TOP HAT SPACER (S1126)

BOLT B - 60° TOP HAT SPACER (S1127)

BOLT C - 360° TOP HAT SPACER (S1124)

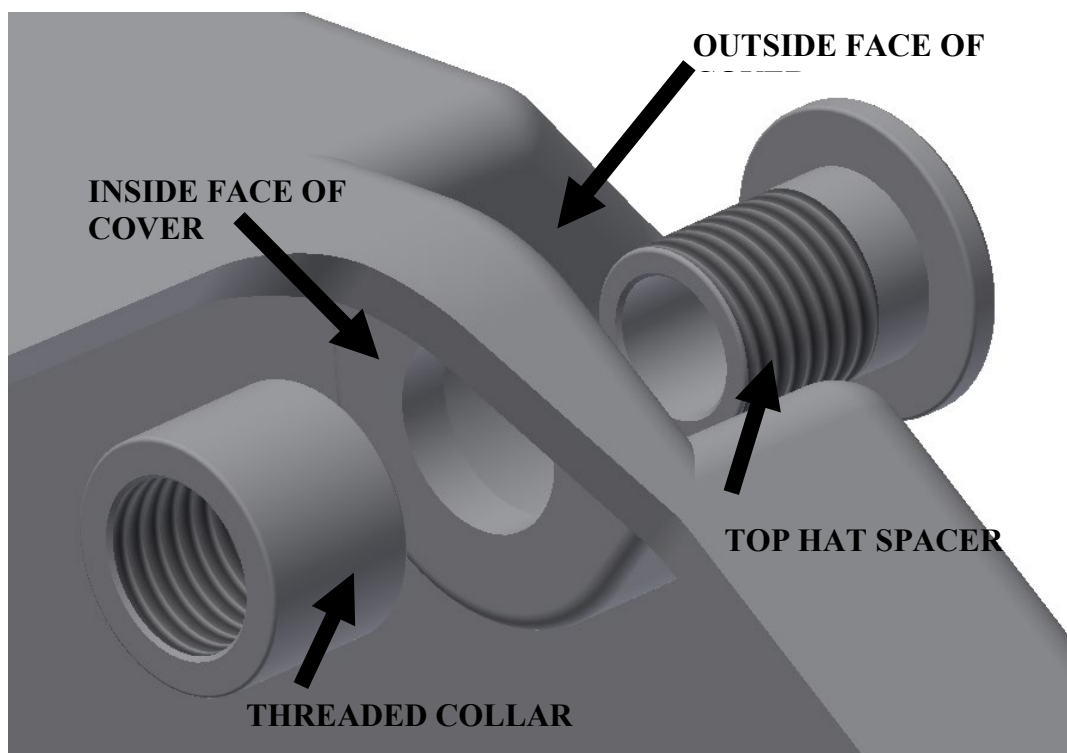

R&G

Unit 1, Shelley's Lane, East Worldham, Alton, Hampshire, GU34 3AQ

Tel: +44 (0)1420 89007 Fax: +44 (0)1420 87301 www.rg-racing.com Email: info@rg-racing.com



- Offer up the R&G cover to the engine and carefully fit it over the casing. Ensure that the three R&G bolts are lined up with the holes in the engine casing, and then push on as far as it will go.
- Fit the bolts through the Engine Case Cover and into the engine case.
- With a 5mm Allen key tighten the bolts equally so that they pull the cover into place. DO NOT FULLY TIGHTEN.
- Finally use a torque wrench set at 10 N/m (7 Lb/ft) to fully tighten.
- It is suggested that you check the tightness of the mounting bolts on a regular basis i.e. when cleaning or once a month.
- NOTE for the cleaning of this product you should only use a soft polishing cloth and a mild general cleaning agent.
- AVOID HARMFUL CHEMICALS. IF IN DOUBT DO NOT USE AS THEY COULD ALTER THE STRENGTH OF THE COVER.
- R&G will accept no liability if the above procedure and torque settings are not followed.

ISSUE 1 29/01/2019 (LF)

GENERAL TORQUE SETTINGS

M4 BOLT = 8Nm
M5 BOLT = 12Nm
M6 BOLT = 15Nm
M8 BOLT = 20Nm
M10 BOLT = 40Nm

CONSUMER NOTICE

The catalogue description and any exhibition of samples are only broad indications of the Products and R&G may make design changes which do not diminish their performance or visual appeal and supplying them in such state shall conform to the order. The Buyer acknowledges no representation or warranty (other than as to title) has been given or will apply to the Products other than those in R&G's order or confirmation and the Buyer confirms it has chosen the Products as being of merchantable quality and suitable for its particular purposes. Where R&G fits the Products or undertakes other services it shall exercise reasonable skill and care and rectify any fault free of charge unless the workmanship has been disturbed. The Buyer is responsible for ensuring that the warranty on the motorcycle is not affected by the fitting of the Products. On return of any defective Products R&G shall at its option either supply a replacement or refund the purchase money but shall not be liable if the Products have been modified or used or maintained otherwise than in accordance with R&G's or manufacturer's instructions and good engineering practice or if the defect arises from accident or neglect. Other than identified above and subject to R&G not limiting its liability for causing death and personal injury, it shall not be liable for indirect or consequential loss and otherwise its liability shall be limited to the amounts paid by the Buyer for the Products or the fitting or service concerned. These terms do not affect the Buyer's statutory rights.

R&G RACING RETURNS POLICY (NON-FAULTY GOODS)

Returns must be pre-authorised (if not pre-authorised the return will be rejected). Goods may only be returned direct to us if they were purchased direct from us (customer must prove if necessary). Otherwise to be returned to original vendor. Goods must be in re-sellable condition, in the opinion of R&G Racing. All returns are subject to a 25% restocking and handling fee (25% of the gross value exc. P&P – at the prevailing price at time of purchase). The customer must pay any and all carriage charges. No returns of discontinued products, unless within 14 days of purchase. This policy does not affect your statutory rights and does not refer to faulty goods.

R&G

Unit 1, Shelley's Lane, East Worldham, Alton, Hampshire, GU34 3AQ
Tel: +44 (0)1420 89007 Fax: +44 (0)1420 87301 www.rg-racing.com Email: info@rg-racing.com



**NOTICE DE MONTAGE POUR ECC0272 DUCATI SCRABLER 1100 2018-
PROTECTION CARTER MOTEUR GAUCHE**

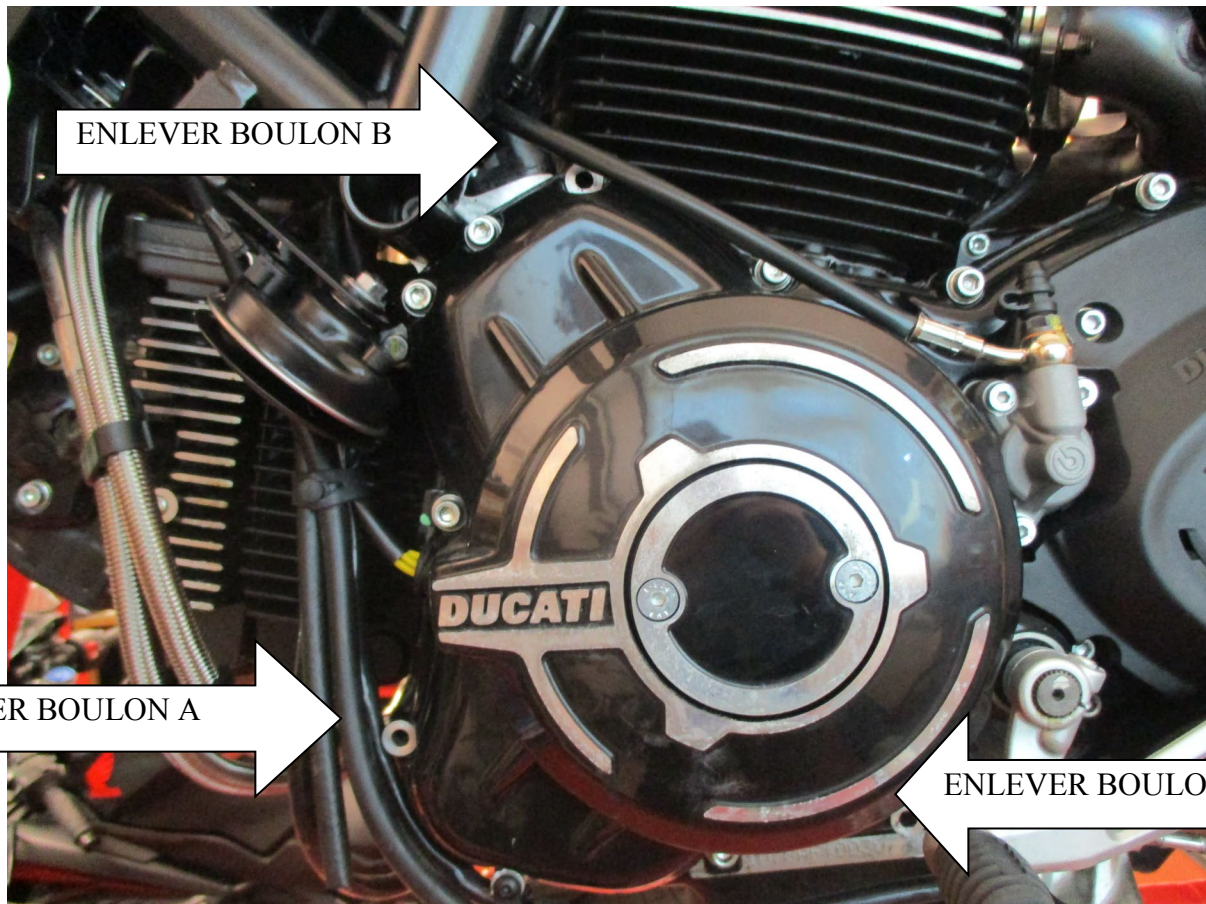

Le kit doit contenir :

- 1x Protection carter moteur (ECC0272)
- 2 x M6 x 40mm Boulons
- 1 x M6 x 45mm Boulon
- 3 x Collier fileté (S1123)
- 1 x 360° Entretoise (S1124)
- 1 x 90° Entretoise (S1126)
- 1 x 60° Entretoise (S1127)

Notice disponible au téléchargement sur www.rg-racing.com



LIRE L'ENSEMBLE DES INSTRUCTIONS AVANT DE COMMENCER

- Assurez-vous que le moteur soit froid.
- Pour monter la protection R&G, enlever les 4 boulons M6 de carter moteur, voir photo ci-dessus. Tenir le couvercle autour du carter pour aider à les identifier. NE PAS ENLEVER TOUS LES BOULONS DE CARTER.
- Insérer les 3 différentes entretoises dans les 3 trous de la protection carter moteur, voir schéma ci-dessous. Veiller à ce qu'elles soient correctement positionnées avant de procéder puis fixer la position en utilisant les colliers filetés. NOTE : Ne pas trop serrer les colliers, car les boulons doivent pouvoir se placer dans les trous du carter moteur.

POSITIONS DES ENTRETOISES

BOULON A - 90° ENTRETOISE (S1126)

BOULON B - 60° ENTRETOISE (S1127)

BOULON C - 360° ENTRETOISE (S1124)

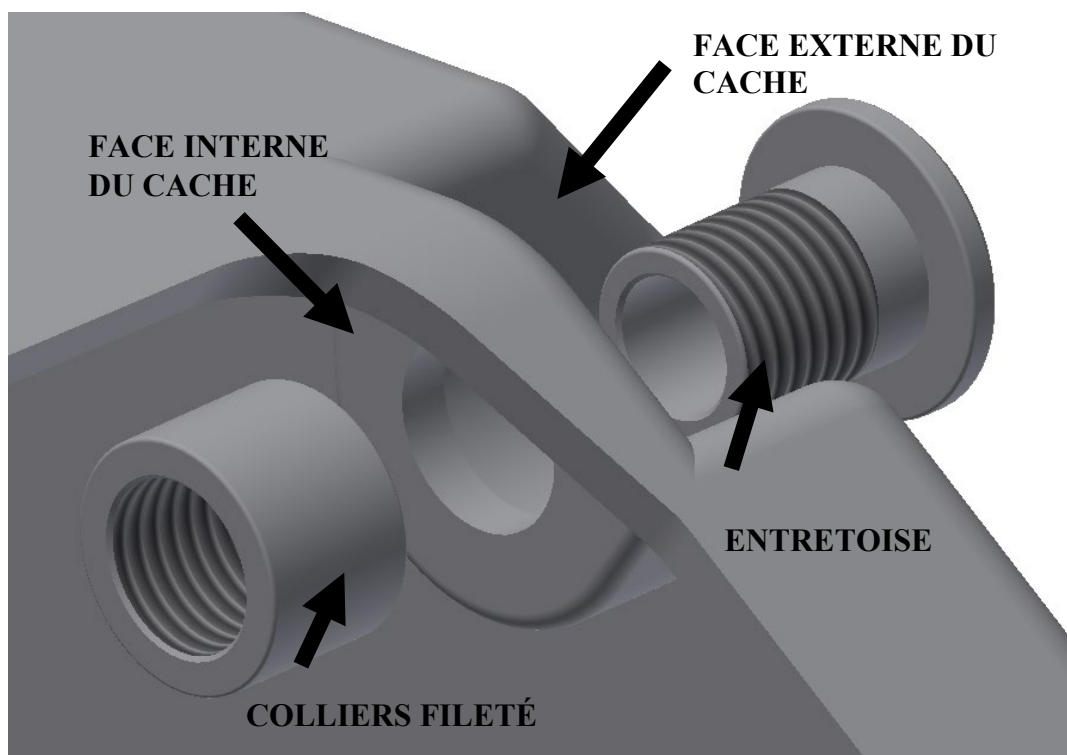



- Monter la protection R&G sur le moteur puis montez la sur le carter. Veiller à ce que les 3 boulons R&G soient alignés avec les trous du carter moteur, puis poussez jusqu'à la limite.
- Insérer les boulons dans la protection carter moteur puis dans le carter moteur.
- Serrer les boulons à la clé Allen 5mm de façon identique de façon à ce que la cache se mette en place. NE PAS SERRER COMPLETEMENT.
- Utiliser une clé dynamométrique à 10 Nm (7 Lb ft) pour bloquer.
- Nous vous suggérons de vérifier le serrage au moins une fois par mois, lors du nettoyage par.
- NOTE : Pour le nettoyage, vous devriez utiliser uniquement un chiffon doux et un agent nettoyant doux.
- Ne pas utiliser d'agents chimiques qui pourraient altérer l'efficacité de la protection.
- R&G n'acceptera aucune responsabilité en cas de mauvais couple de serrage ou d'utilisation inappropriée d'agents nocif.

ISSUE 1 29/01/2019 (LF)

VALEURS DE SERRAGE RECOMMANDEES

M4 BOULON = 8Nm
M5 BOULON = 12Nm
M6 BOULON = 15Nm
M8 BOULON = 20Nm
M10 BOULON = 40Nm

CONSUMER NOTICE

The catalogue description and any exhibition of samples are only broad indications of the Products and R&G may make design changes which do not diminish their performance or visual appeal and supplying them in such state shall conform to the order. The Buyer acknowledges no representation or warranty (other than as to title) has been given or will apply to the Products other than those in R&G's order or confirmation and the Buyer confirms it has chosen the Products as being of merchantable quality and suitable for its particular purposes. Where R&G fits the Products or undertakes other services it shall exercise reasonable skill and care and rectify any fault free of charge unless the workmanship has been disturbed. The Buyer is responsible for ensuring that the warranty on the motorcycle is not affected by the fitting of the Products. On return of any defective Products R&G shall at its option either supply a replacement or refund the purchase money but shall not be liable if the Products have been modified or used or maintained otherwise than in accordance with R&G's or manufacturer's instructions and good engineering practice or if the defect arises from accident or neglect. Other than identified above and subject to R&G not limiting its liability for causing death and personal injury, it shall not be liable for indirect or consequential loss and otherwise its liability shall be limited to the amounts paid by the Buyer for the Products or the fitting or service concerned. These terms do not affect the Buyer's statutory rights.

R&G RACING RETURNS POLICY (NON-FAULTY GOODS)

Returns must be pre-authorized (if not pre-authorized the return will be rejected). Goods may only be returned direct to us if they were purchased direct from us (customer must prove if necessary). Otherwise to be returned to original vendor. Goods must be in re-sellable condition, in the opinion of R&G Racing. All returns are subject to a 25% restocking and handling fee (25% of the gross value exc. P&P – at the prevailing price at time of purchase). The customer must pay any and all carriage charges. No returns of discontinued products, unless within 14 days of purchase. This policy does not affect your statutory rights and does not refer to faulty goods.

R&G

Unit 1, Shelley's Lane, East Worldham, Alton, Hampshire, GU34 3AQ
Tel: +44 (0)1420 89007 Fax: +44 (0)1420 87301 www.rg-racing.com Email: info@rg-racing.com



**MONTAGEANLEITUNG FÜR ECC0272 DUCATI SCRABLER 1100 2018-
MOTORGEHÄUSE-ABDECKUNG – LINKE SEITE**

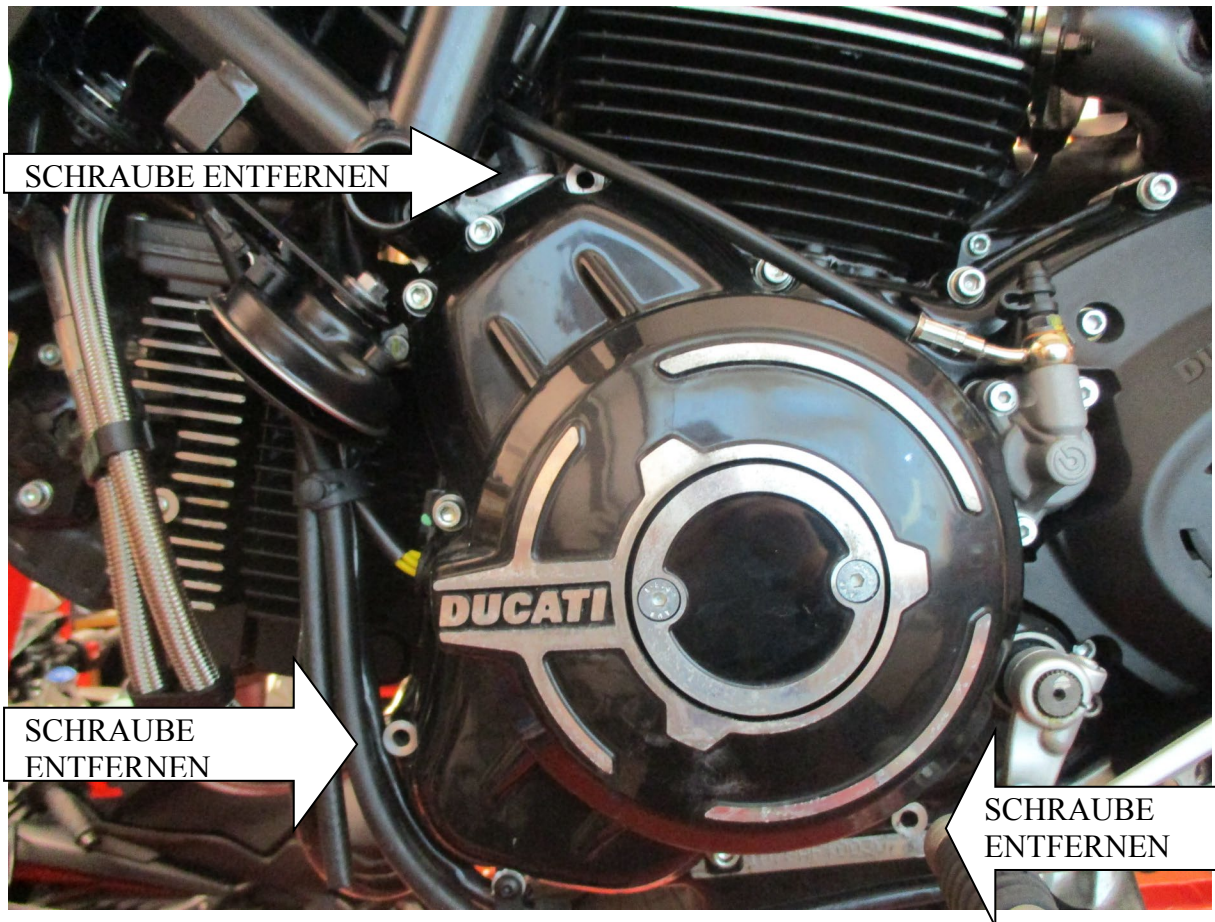

INHALT DES KITS:

- 1x MOTORGEHÄUSE-ABDECKUNG (ECC0272)
- 2 x M6 x 40mm INBUSSCHRAUBEN
- 1 x M6 x 45mm INBUSSCHRAUBE
- 3 x SCHLIESSRING MIT GEWINDE (S1123)
- 1 x 360° HUT-DISTANZHALTER (S1124)
- 1 x 90° HUT-DISTANZHALTER (S1126)
- 1 x 60° HUT-DISTANZHALTER (S1127)

Eine digitale Version dieser Montageanleitung kann auf folgender Seite heruntergeladen werden: www.rg-racing.com



BITTE LESEN SIE DIE MONTAGEANLEITUNG DURCH, BEVOR SIE MIT DER MONTAGE BEGINNEN.

- Bitte achten Sie unbedingt darauf, dass der Motor kalt ist, bevor Sie mit der Montage der R&G Abdeckung beginnen.
- Um die R&G Motorgehäuse-Abdeckung montieren zu können, entfernen Sie die drei M6 Motorgehäuse-Schrauben, die oben gekennzeichnet sind. Um die richtigen Schrauben identifizieren zu können, halten Sie die Abdeckung an das Gehäuse. **ENTFERNEN SIE NICHT ALLE SCHRAUBEN AM MOTORGEHÄUSE.**
- Montieren Sie die drei Hut-Distanzhalter an den drei Öffnungen in der Motorgehäuse-Abdeckung wie unten abgebildet. Bitte stellen Sie sicher, dass sie richtig positioniert sind, bevor Sie fortfahren, dann mit den Schließringen in Position sichern. Die Schließringe mit Gewinde nicht überziehen, da die Schrauben noch in die Öffnungen an der Motorgehäuse-Abdeckung eingeführt werden müssen.

DISTANZHALTER POSITIONEN

BOLT A - 90° HUT-DISTANZHALTER (S1126)

BOLT B - 60° HUT-DISTANZHALTER (S1127)

BOLT C - 360° HUT-DISTANZHALTER (S1124)

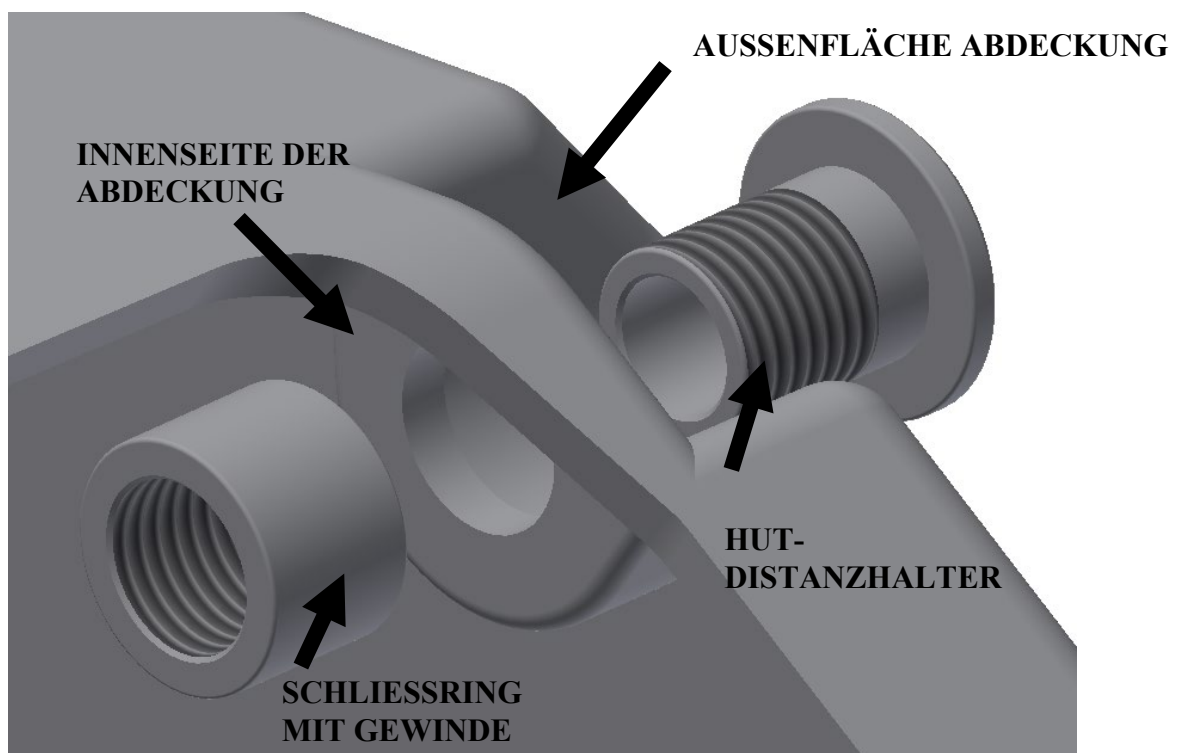

R&G

Unit 1, Shelley's Lane, East Worldham, Alton, Hampshire, GU34 3AQ
Tel: +44 (0)1420 89007 Fax: +44 (0)1420 87301 www.rg-racing.com Email: info@rg-racing.com



- Die R&G Abdeckung an den Motor ansetzen und vorsichtig am Gehäuse anbringen. Achten Sie darauf, dass die drei R&G Schrauben mit den Bohrungen im Motorgehäuse ausgerichtet sind, dann die Abdeckung soweit wie möglich eindrücken.
- Die Schrauben durch die Motorgehäuse-Abdeckung ins Motorgehäuse einführen.
- Ziehen Sie die Schrauben mit einem 5mm Inbusschlüssel gleichmäßig an, sodass sie die Abdeckung in Position ziehen. NICHT FESTZIEHEN.
- Anschließend benutzen Sie einen Drehmomentschlüssel, der auf 10 N/m (7 Lb/ft) eingestellt ist, um die Schrauben festzuziehen.
- Es wird empfohlen, die Festigkeit der Schrauben in regelmäßigen Abständen zu kontrollieren (d.h. einmal im Monat).
- HINWEIS: Bei der Reinigung dieses Produkts benutzen Sie nur ein weiches Poliertuch und ein mildes Putzmittel.
- VERMEIDEN SIE SCHÄDLICHE CHEMIKALIEN. IM ZWEIFELSFALL NICHT BENUTZEN, DA SIE DIE FESTIGKEIT DER ABDECKUNG VERÄNDERN KÖNNEN.
- R&G übernimmt keine Haftung, wenn die obengenannten Schritte nicht eingehalten werden und/oder die angegebenen Anzugsdrehmomente nicht angewendet werden.

AUSGABE 1 29/01/2019 (LF)

ANZUGSDREHMOMENT

M4 SCHRAUBE = 8Nm

M5 SCHRAUBE = 12Nm

M6 SCHRAUBE = 15Nm

M8 SCHRAUBE = 20Nm

M10 SCHRAUBE = 40Nm

CONSUMER NOTICE

The catalogue description and any exhibition of samples are only broad indications of the Products and R&G may make design changes which do not diminish their performance or visual appeal and supplying them in such state shall conform to the order. The Buyer acknowledges no representation or warranty (other than as to title) has been given or will apply to the Products other than those in R&G's order or confirmation and the Buyer confirms it has chosen the Products as being of merchantable quality and suitable for its particular purposes. Where R&G fits the Products or undertakes other services it shall exercise reasonable skill and care and rectify any fault free of charge unless the workmanship has been disturbed. The Buyer is responsible for ensuring that the warranty on the motorcycle is not affected by the fitting of the Products. On return of any defective Products R&G shall at its option either supply a replacement or refund the purchase money but shall not be liable if the Products have been modified or used or maintained otherwise than in accordance with R&G's or manufacturer's instructions and good engineering practice or if the defect arises from accident or neglect. Other than identified above and subject to R&G not limiting its liability for causing death and personal injury, it shall not be liable for indirect or consequential loss and otherwise its liability shall be limited to the amounts paid by the Buyer for the Products or the fitting or service concerned. These terms do not affect the Buyer's statutory rights.

R&G RACING RETURNS POLICY (NON-FAULTY GOODS)

Returns must be pre-authorized (if not pre-authorized the return will be rejected). Goods may only be returned direct to us if they were purchased direct from us (customer must prove if necessary). Otherwise to be returned to original vendor. Goods must be in re-sellable condition, in the opinion of R&G Racing. All returns are subject to a 25% restocking and handling fee (25% of the gross value exc. P&P – at the prevailing price at time of purchase). The customer must pay any and all carriage charges. No returns of discontinued products, unless within 14 days of purchase. This policy does not affect your statutory rights and does not refer to faulty goods.

R&G

Unit 1, Shelley's Lane, East Worldham, Alton, Hampshire, GU34 3AQ

Tel: +44 (0)1420 89007 Fax: +44 (0)1420 87301 www.rg-racing.com Email: info@rg-racing.com