



LP0176

**FITTING INSTRUCTIONS FOR LP0176BK LICENCE PLATE BRACKET**  
**BMW S1000 RR 2015-**

Page | 1



**THIS KIT CONTAINS THE ITEMS PICTURED AND LABELLED BELOW.**  
**DO NOT PROCEED UNTIL YOU ARE SURE ALL PARTS ARE PRESENT.**

**Please note that the way the kit is packed does not necessarily represent the way of mounting to the bike**

**THE PARTS SHOWN MAY BE REPRESENTATIVE ONLY (FOR CLARITY OF INSTRUCTIONS ONLY)**

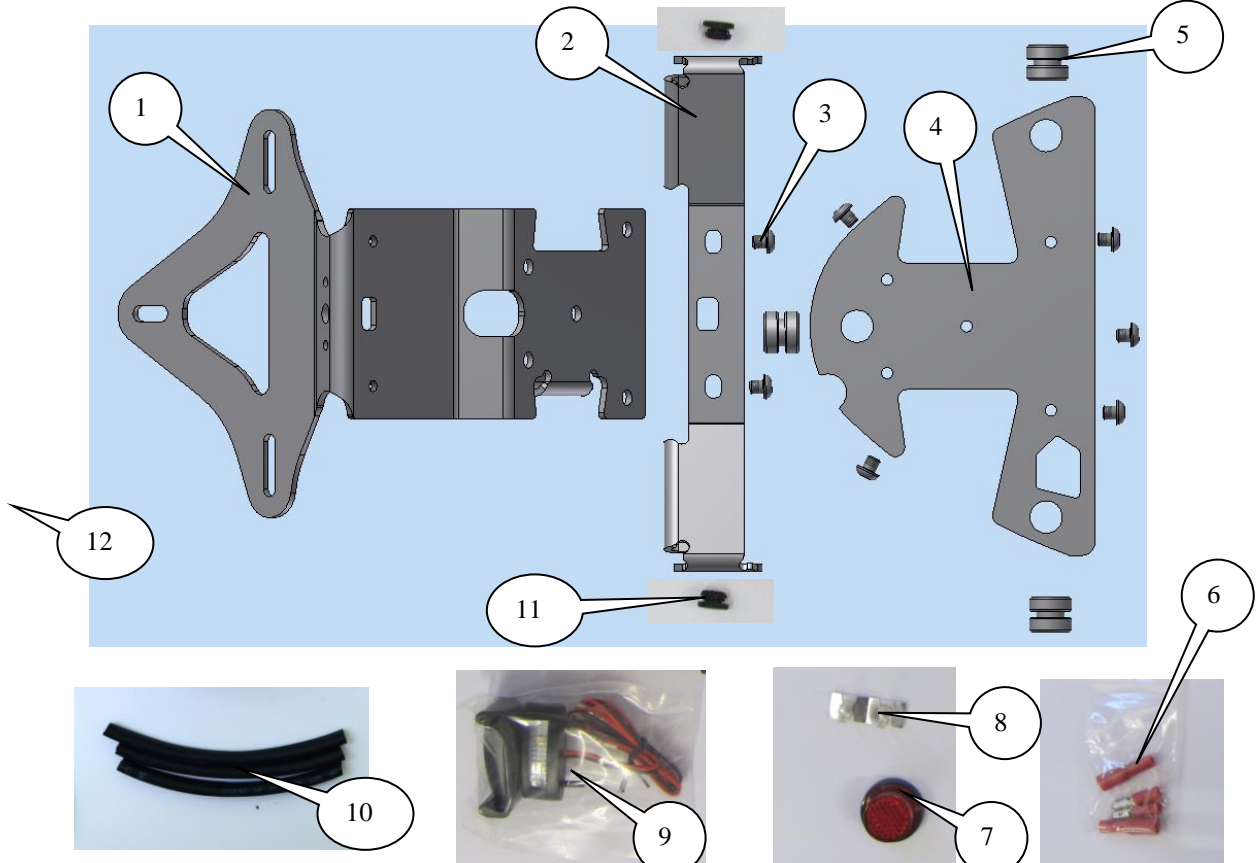

R&G Racing  
Unit 1, Shelleys Lane, East Worldham, Alton, Hampshire, GU34 3AQ

Tel: +44 (0) 1420 89007 | Fax : +44 (0) 1420 87301 | Email: info@rg-racing.com



LP0176

### **LEGEND**

- ITEM 1= LICENCE PLATE BRACKET (TB0176 PT1) (x1).  
ITEM 2= INDICATOR MOUNTING PLATE (TB0176 PT2) (x1).  
ITEM 3= M6x6mm LONG BUTTON HEAD BOLTS (x7).  
ITEM 4= LICENCE PLATE ADAPTOR PLATE (TB0092 PT1) (x1).  
ITEM 5= RUBBER GROMMETS (RB0003) (x3).  
ITEM 6= BAG OF ELECTRICAL CONNECTORS (CON4) (x1).  
ITEM 7= REFLECTIVE (REFL1) (x1).  
LIGHT SHROUD (LH0004) (x1).  
ITEM 8= CABLE CLIPS (CLIP1) (x5).  
ITEM 9= LICENCE PLATE LIGHT ASSEMBLY (LA0002) (x1).  
ITEM 10=250mm LENGTH OF HEAT SHRINK (666-896) (x1).  
ITEM 11= SMALL RUBBER GROMMETS (RB80-30-00) (x2).  
ITEM 12= M6 WASHERS (x2) NOT SHOWN.

Page | 2

Please note that in cases where kits are packed with rubber washers holding the components onto the bolt – *the rubber washers should be thrown away!*

### **TOOLS REQUIRED**

- Set of metric Allen keys to include 4mm A/F sizes.
- Set of Torx keys to include T20 and T25 sizes.
  - Electrical pliers/crimps.
  - Super glue.

### **FITTING INSTRUCTIONS**



PICTURE 1

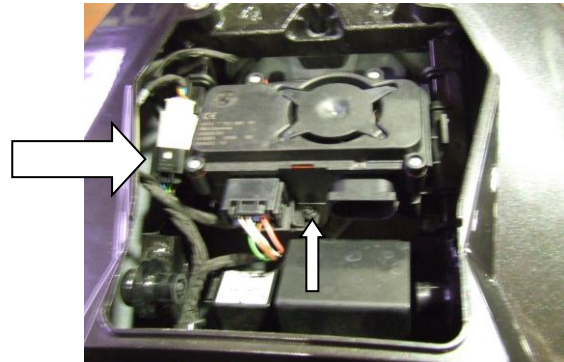

PICTURE 2

- REMOVE PILLION SEAT USING KEY (SEE PICTURE 1).
- UNCLIP AND DISCONNECT WIRING PLUG (LARGER ARROW IN PICTURE 2).
- UNDO AND REMOVE CLAMP SCREW (SMALLER ARROW IN PICTURE 2).
- UNCLIP ALARM FROM ITS MOUNTING BRACKET (DO NOT UNPLUG) AND REST ON FUSE BOX (TO ALLOW ACCESS TO ALARM MOUNTING BRACKET).
- REMOVE PLASTIC ALARM MOUNTING BRACKET (GENTLY SQUEEZE AND TWIST TO UNCLIP FROM REAR SUB-FRAME). THIS ALLOWS CABLE TO GO THROUGH ACCESS HOLE.
- REMOVE THREE BOLTS FROM THE UNDERSIDE (SEE PICTURE 3 FOR POSITION) TO ALLOW ORIGINAL LICENCE PLATE BRACKET TO BE

R&G Racing  
Unit 1, Shelleys Lane, East Worldham, Alton, Hampshire, GU34 3AQ

Tel: +44 (0) 1420 89007 | Fax : +44 (0) 1420 87301 | Email: info@rg-racing.com



LP0176

REMOVED (KEEP THE BOLTS AS THESE ARE REUSED TO MOUNT NEW LICENCE PLATE ADAPTOR PLATE).

- INSERT THE THREE LARGER RUBBER GROMMETS INTO THE LICENCE PLATE ADAPTOR PLATE (SEE PICTURE 4), AN APPLICATION OF WASHING UP LIQUID AIDS THIS PROCESS.

Page | 3

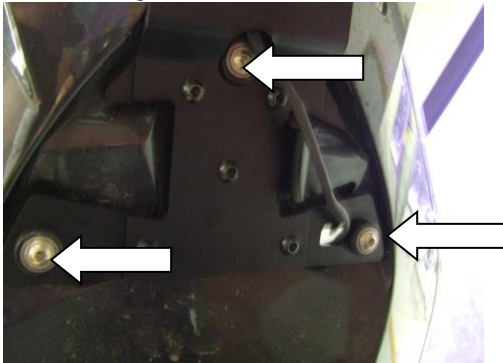

PICTURE 3



PICTURE 4

- MOUNT THE LICENCE PLATE ADAPTOR PLATE ONTO MOUNTING SPIGOTS AS THE ORIGINAL WAS MOUNTED AND USING THE ORIGINAL BOLTS SECURE IN POSITION (SEE PICTURE 3).
- IF USING ORIGINAL INDICATORS (TURN SIGNALS), REMOVE FROM ORIGINAL LICENCE PLATE BRACKET AND FIT TO NEW INDICATOR MOUNTING PLATE AS ORIGINAL (YOU WILL HAVE TO STRIP BACK THE WIRING LOOM TO SEPARATE WIRES FOR THE REMOVAL PROCESS).
- FIT THE INDICATORS OF CHOICE (R&G MINI INDICATOR PRODUCT CODE RG370 FOR BULB AND RG371 FOR LED TYPE OR RG372 FOR AERO STYLE LED TYPE) TO THE INDICATOR MOUNTING PLATE AND SECURE USING TWO OF THE M6x6mm LONG BUTTON HEADS TO MOUNT THE INDICATOR MOUNTING PLATE AS SHOWN IN THE TOP PICTURE ON LEFT.
- FIT NEW LICENCE PLATE LIGHT TO NEW LICENCE PLATE BRACKET (SEE PICTURE 5). WE SUGGEST CUTTING AND SPLICING INTO ORIGINAL PLUG SOCKET USING THE CONNECTORS FROM KIT. PROTECT WIRES USING HEAT SHRINK FROM KIT.

THE ORIGINAL GREEN WIRE -----NEW RED WIRE.

THE ORIGINAL BROWN WIRE (EARTH) -----NEW BLACK WIRE.

- **PLEASE NOTE YOU WILL NEED TO GLUE THE LIGHT SHROUD TO THE LED LICENCE PLATE LIGHT BEFORE FITTING, USING SUPER GLUE.**
- FEED THE LICENCE PLATE LIGHT WIRE THROUGH THE RECTANGULAR HOLE IN THE NEW LICENCE PLATE BRACKET AND THEN THROUGH THE OVAL HOLE (SEE PICTURE 5).
- MOUNT THE NEW LICENCE PLATE BRACKET ONTO THE LICENCE PLATE ADAPTOR PLATE USING THE FIVE M6x6mm LONG BUTTON HEAD BOLTS AND SECURE (SEE PICTURE 3).
- FEED ALL WIRES THROUGH THE IRREGULAR SHAPED HOLE IN THE LICENCE PLATE ADAPTOR PLATE AND THROUGH THE BODY WORK INTO THE UNDER-SEAT STORAGE SPACE (SEE PICTURE 6).

R&G Racing

Unit 1, Shelleys Lane, East Worldham, Alton, Hampshire, GU34 3AQ

Tel: +44 (0) 1420 89007 | Fax : +44 (0) 1420 87301 | Email: info@rg-racing.com



LP0176

Page | 4



PICTURE 5

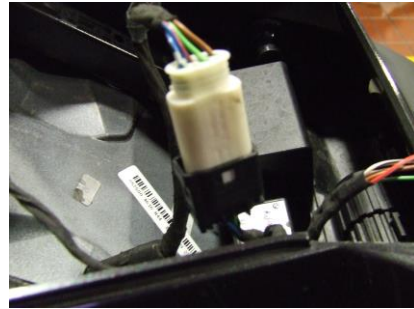

PICTURE 6

- CONNECT WIRING PLUG SOCKETS AS ORIGINAL (IF THE LICENCE PLATE ILLUMINATOR FAILS TO WORK PLEASE SWOP THE CONNECTORS OVER).
- REFIT ALARM MOUNTING BRACKET AS ORIGINAL.
- REMOUNT AND SECURE ALARM AS ORIGINAL.
- REFIT PILLION SEAT.
- REFIT LICENCE PLATE (IT MAY REQUIRE DRILLING).
- **IMPORTANT: IF FITTING A FULL-SIZE LICENCE PLATE AND PLACING IT FAR DOWN ON THE LICENCE PLATE HANGER, THERE IS A SMALL CHANCE OF THE LICENCE PLATE HITTING THE BACK WHEEL UNDER HEAVY LOAD AND OVER LARGE BUMPS IN THE ROAD. IT IS YOUR RESPONSIBILITY TO CHECK FOR THIS POSSIBILITY AND TAKE AVOIDING ACTION. FAILURE TO CHECK THIS COULD RESULT IN SERIOUS INJURY.**
- DEPENDING ON LOCAL LAWS, ATTACH ENCLOSED RED REFLECTIVE TAPE IN AN APPROPRIATE LOCATION.
- TEST THE INDICATORS (TURN SIGNALS) (DEPENDING ON THE TYPE OF INDICATORS BEING USED YOU MAY HAVE TO USE RESISTORS TO GET THE CORRECT FLASH RATE), LICENCE PLATE ILLUMINATOR AND ALL LIGHTS BEFORE RIDING.

#### CONSUMER NOTICE

The catalogue description and any exhibition of samples are only broad indications of the Products and R&G may make design changes which do not diminish their performance or visual appeal and supplying them in such state shall conform to the order. The Buyer acknowledges no representation or warranty (other than as to title) has been given or will apply to the Products other than those in R&G's order or confirmation and the Buyer confirms it has chosen the Products as being of merchantable quality and suitable for its particular purposes. Where R&G fits the Products or undertakes other services it shall exercise reasonable skill and care and rectify any fault free of charge unless the workmanship has been disturbed. The Buyer is responsible for ensuring that the warranty on the motorcycle is not affected by the fitting of the Products. On return of any defective Products R&G shall at its option either supply a replacement or refund the purchase money but shall not be liable if the Products have been modified or used or maintained otherwise than in accordance with R&G's or manufacturer's instructions and good engineering practice or if the defect arises from accident or neglect. Other than identified above and subject to R&G not limiting its liability for causing death and personal injury, it shall not be liable for indirect or consequential loss and otherwise its liability shall be limited to the amounts paid by the Buyer for the Products or the fitting or service concerned. These terms do not affect the Buyer's statutory rights.

#### R&G RACING RETURNS POLICY (NON-FAULTY GOODS)

Returns must be pre-authorized (if not pre-authorized the return will be rejected). Goods may only be returned direct to us if they were purchased direct from us (customer must prove if necessary). Otherwise to be returned to original vendor. Goods must be in re-sellable condition, in the opinion of R&G Racing. All returns are subject to a 25% restocking and handling fee (25% of the

R&G Racing

Unit 1, Shelleys Lane, East Worldham, Alton, Hampshire, GU34 3AQ

Tel: +44 (0) 1420 89007 | Fax : +44 (0) 1420 87301 | Email: info@rg-racing.com



LP0176

gross value exc. P&P – at the prevailing price at time of purchase). The customer must pay any and all carriage charges. No returns of discontinued products, unless within 14 days of purchase. This policy does not affect your statutory rights and does not refer to faulty goods.



LP0176

**INSTRUCTIONS DE MONTAGE POUR LP0176BK SUPPORT DE PLAQUE  
BMW S1000 RR 2015-**

Page | 6



**Assurez vous que toutes les pièces soient présentes avant de procéder au montage.**

**La façon dont le kit est emballé ne correspond pas forcément à la façon de monter les pièces sur la moto.**

LES PIECES PRESENTEES PEUVENT N'ETRE QUE REPRESENTATIVES, AFIN DE FACILITER ET CLARIFIER LES INSTRUCTIONS DE MONTAGE.

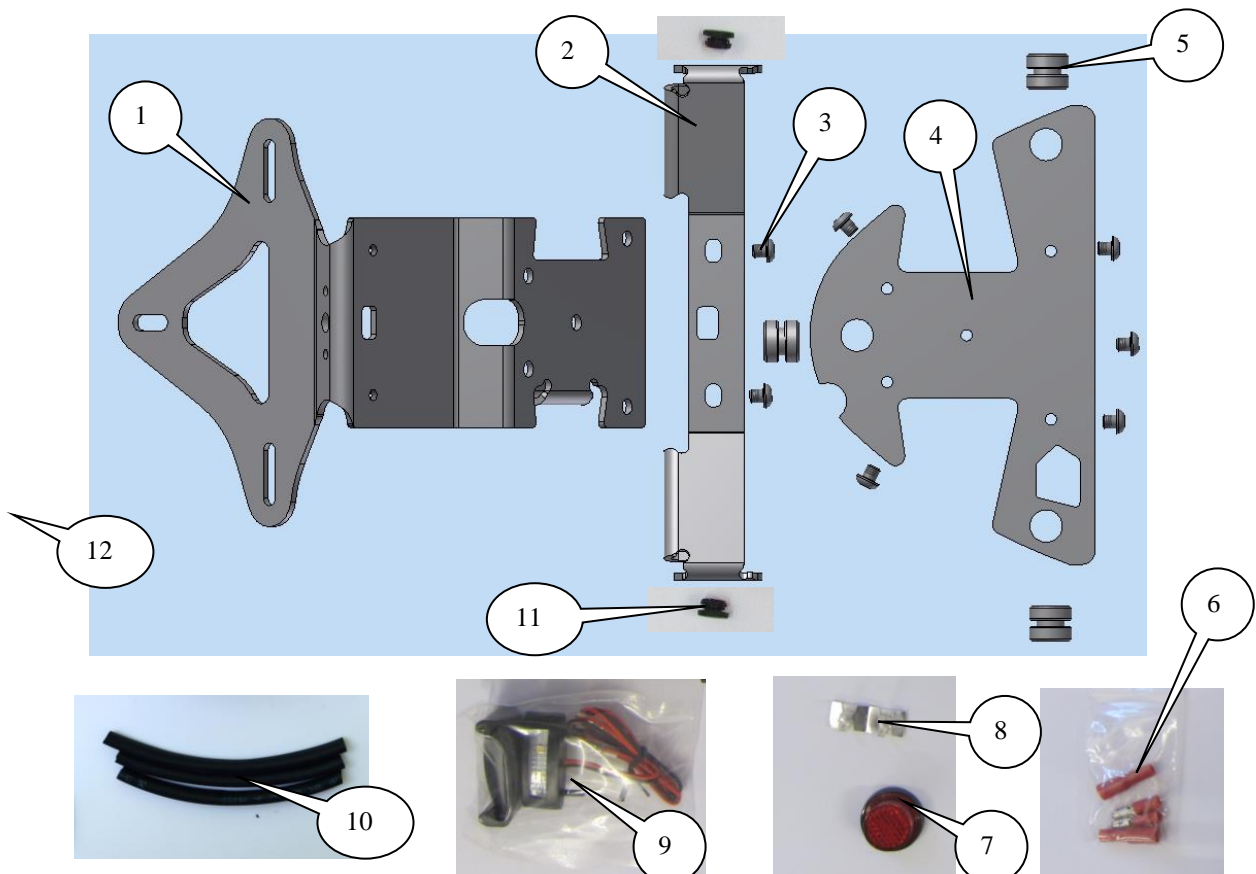

Unit 1, Shelleys Lane, East Worldham, Alton, Hampshire, GU34 3AQ

Tel: +44 (0) 1420 89007 | Fax : +44 (0) 1420 87301 | Email: info@rg-racing.com



LP0176

### LEGENDE

- ARTICLE 1= SUPPORT DE PLAQUE (TB0176 PT1) (x1).  
ARTICLE 2= PLAQUE DE FIXATION CLIGNOTANT (TB0176 PT2) (x1).  
ARTICLE 3= M6x6mm BOULONS (x7).  
ARTICLE 4= PLAQUE D'ADAPTATION DE PLAQUE (TB0092 PT1) (x1).  
ARTICLE 5= RONDELLES DE CAOUTCHOUC (RB0003) (x3).  
ARTICLE 6= SAC DE CONNECTEURS ELECTRIQUES (CON4) (x1).  
ARTICLE 7= REFLECTEUR (REFL1) (x1).  
LINCEUL DE LUMIERE (LH0004) (x1).  
ARTICLE 8= SERRE CABLE (CLIP1) (x5).  
ARTICLE 9= ASSEMBLAGE FEU DE PLAQUE (LA0002) (x1).  
ARTICLE 10=250mm LONGUEUR DE THERMO RETRACTABLE (666-896) (x1).  
ARTICLE 11= PETITES RONDELLES DE CAOUTCHOUC (RB80-30-00) (x2).  
ARTICLE 12= M6 RONDELLES (x2) NON INDIQUE.

Page | 7

Notez que si les kits sont emballés avec des rondelles en caoutchouc servant à tenir les composants, *ces rondelles doivent être jetées.*

### OUTILS REQUIS

- Jeu de clés Allen 4mm.
- Clés Torx T20 et T25.
- Pincés électriques.
- Superglue.

### INSTRUCTIONS DE MONTAGE



PHOTO 1

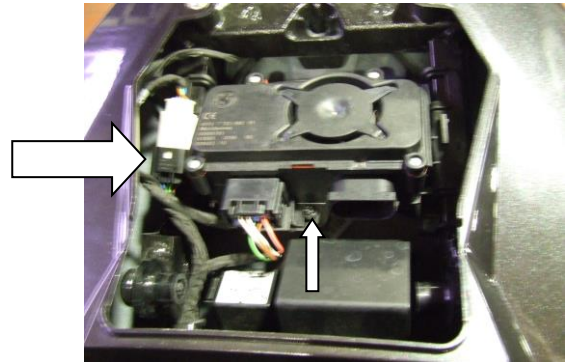

PHOTO 2

- ENLEVER LE SIEGE PASSAGER A L'AIDE DE LA CLE (PHOTO 1).
- DECONNECTER LA PRISE (LA GRANDE FLECHE SUR LA PHOTO 2).
- ENLEVER LA VIS DE SERRAGE (LA PETITE FLECHE SUR LA PHOTO 2).
- DEBLOQUER L'ALARME DE SON SUPPORT (NE PAS LA DEBRANCHER) PUIS POSEZ LA SUR LA BOITE DE FUSIBLES (POUR PERMETTRE L'ACCES AU SUPPORT DE FIXATION ALARME).
- ENLEVER LE SUPPORT DE FIXATION DE L'ALARME (PINCEZ ET TOURNEZ POUR LE DELOGER DU SOUS CADRE ARRIERE). CELA PERMETTRA AU CABLE DE PASSER DANS LE TROU ACCESSIBLE.

R&G Racing  
Unit 1, Shelleys Lane, East Worldham, Alton, Hampshire, GU34 3AQ

Tel: +44 (0) 1420 89007 | Fax : +44 (0) 1420 87301 | Email: info@rg-racing.com



LP0176

- ENLEVER LES 3 BOULONS PAR DESSOUS (PHOTO 3 POUR LA POSITION) POUR PERMETTRE AU SUPPORT DE PLAQUE D'ORIGINE DE S'ENLEVER (CONSERVEZ LES BOULONS CAR ILS SERONT REUTILISES POUR FIXER LA NOUVELLE PLAQUE D'ADAPTATION DE PLAQUE).
- INSEREZ LES 3 PLUS GROSSES RONDELLES DANS LA PLAQUE D'ADAPTATION DE PLAQUE (PHOTO 4), POUR FACILIER CE PROCEDE, APPLIQUEZ UN PEU DE PRODUITS VAISSELLES.

Page | 8

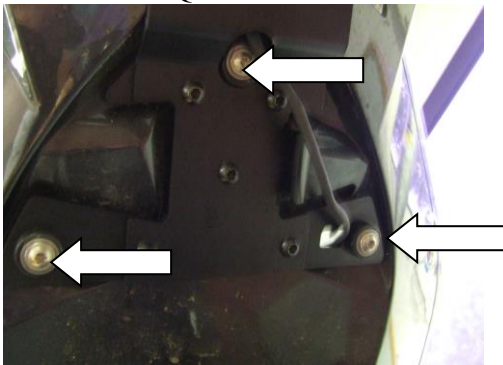

PHOTO 3



PHOTO 4

- FIXER LA PLAQUE D'ADAPTATION DE PLAQUE SUR LES ERGOTS DE FIXATION TOUT COMME L'ORIGINALE ETAIT FIXEE PUIS UTILISER LES BOULONS D'ORIGINE POUR FIXER LA POSITION (PHOTO 3).
- SI VOUS UTILISEZ LES CLIGNOTANTS D'ORIGINE, ENLEVEZ LES DU SUPPORT DE PLAQUE D'ORIGINE PUIS MONTEZ LES SUR LA NOUVELLE PLAQUE DE FIXATION DE CLIGNOTANTS COMME A L'ORIGINE (VOUS DEVREZ DENUDER LES FILS POUR LES SEPARER).
- MONTEZ LES CLIGNOTANTS DE VOTRE CHOIX (LES MINI CLIGNOTANTS R&G, CODE RG370 POUR TYPE AMPOULE ET RG371 POUR TYPE LED OU ENCORE RG372 POUR CLIGNOTANTS LATERAUX A LED) SUR LA PLAQUE DE FIXATION DE CLIGNOTANTS PUIS FIXER A L'AIDE DE DEUX DES BOULONS M6x6mm POUR MONTER LA PLAQUE DE FIXATION DE CLIGNOTANT COMME INDIQUE SUR LA PHOTO EN HAUT A GAUCHE.
- MONTER LE NOUVEAU FEU DE PLAQUE SUR LE SUPPORT DE PLAQUE (PHOTO 5). NOUS SUGGERONS DE COUPER PUIS D'EPISER DANS LA PRISE D'ORIGINE A L'AIDE DES CONNECTEURS DU KIT.
- APPLIQUEZ LA GAINE THERMO RETRACTABLE POUR PROTEGER LES FILS.  
LE FIL VERT D'ORIGINE -----NOUVEAU FIL ROUGE.  
LE FIL MARRON D'ORIGINE (TERRE) -----NOUVEAU FIL NOIR.
- **VOUS DEVREZ COLLER LE LINCEUL DE FEU AU FEU DE PLAQUE LED A L'AIDE DE LA SUPERGLUE.**
- PASSEZ LE FIL DE FEU DE PLAQUE DANS LE TROU RECTANGULAIRE DU NOUVEAU SUPPORT DE PLAQUE PUIS DANS LE TROU OVAL (PHOTO 5).
- FIXER LE NOUVEAU SUPPORT ADAPTATEUR DE PLAQUE EN UTILISANT LES CINQ BOULONS M6x6mm PUIS SERRER (PHOTO 3).
- PASSEZ TOUS LES FILS DANS LE TROU DE FORME IRRÉGULIÈRE DANS LA PLAQUE D'ADAPTATEUR DE PLAQUE PUIS DANS LE CARENAGE, A TRAVERS L'ESPACE DE STOCKAGE (PHOTO 6).

R&G Racing

Unit 1, Shelleys Lane, East Worldham, Alton, Hampshire, GU34 3AQ

Tel: +44 (0) 1420 89007 | Fax : +44 (0) 1420 87301 | Email: info@rg-racing.com





LP0176

Page | 9



PHOTO 5

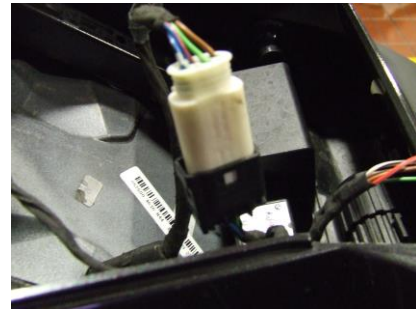

PHOTO 6

- CONNECTEZ LES PRISES COMME A L'ORIGINE (SI LE FEU DE PLAQUE NE S'ALLUME PAS, TOURNEZ LES CONNECTEURS).
- REMETTRE LE SUPPORT DE FIXATION ALARME COMME A L'ORIGINE.
- REMONTEZ ET FIXEZ L'ALARME COMME A L'ORIGINE.
- REMETTRE LE SIEGE PASSAGE.
- REMETTRE LA PLAQUE (PEUT NECESSITER UN PERCAGE).
- **IMPORTANT:** Si vous installez une grosse plaque, il y a un risque que la plaque entre en contact avec la roue arrière en cas de choc sur la route (bosse, grosse charge etc...). Il est de votre responsabilité de vérifier que cela ne puisse pas se produire. Ne pas effectuer ces vérifications peut entrainer des dommages ainsi que des blessures graves pour le pilote.
- SELON LES LOIS LOCALES, ATTACHEZ DES REFLECTEURS ROUGE AUX EMBLEMES APPROPRIES.
- TESTEZ LES CLIGNOTANTS, ET SELON LE TYPE DE CLIGNOTANTS UTILISES, UTILISEZ OU NON DES RESISTANCES (AFIN D'OBTENIR UN NIVEAU D'ECLAIRAGE CORRECTE), LE FEU DE PLAQUE, AINSI QUE TOUS LES AUTRES FEUX AVANT DE PRENDRE LA ROUTE.

#### CONSUMER NOTICE

The catalogue description and any exhibition of samples are only broad indications of the Products and R&G may make design changes which do not diminish their performance or visual appeal and supplying them in such state shall conform to the order. The Buyer acknowledges no representation or warranty (other than as to title) has been given or will apply to the Products other than those in R&G's order or confirmation and the Buyer confirms it has chosen the Products as being of merchantable quality and suitable for its particular purposes. Where R&G fits the Products or undertakes other services it shall exercise reasonable skill and care and rectify any fault free of charge unless the workmanship has been disturbed. The Buyer is responsible for ensuring that the warranty on the motorcycle is not affected by the fitting of the Products. On return of any defective Products R&G shall at its option either supply a replacement or refund the purchase money but shall not be liable if the Products have been modified or used or maintained otherwise than in accordance with R&G's or manufacturer's instructions and good engineering practice or if the defect arises from accident or neglect. Other than identified above and subject to R&G not limiting its liability for causing death and personal injury, it shall not be liable for indirect or consequential loss and otherwise its liability shall be limited to the amounts paid by the Buyer for the Products or the fitting or service concerned. These terms do not affect the Buyer's statutory rights.

R&G Racing  
Unit 1, Shelleys Lane, East Worldham, Alton, Hampshire, GU34 3AQ

Tel: +44 (0) 1420 89007 | Fax : +44 (0) 1420 87301 | Email: info@rg-racing.com



LP0176

**R&G RACING RETURNS POLICY (NON-FAULTY GOODS)**

Returns must be pre-authorized (if not pre-authorized the return will be rejected). Goods may only be returned direct to us if they were purchased direct from us (customer must prove if necessary). Otherwise to be returned to original vendor. Goods must be in re-sellable condition, in the opinion of R&G Racing. All returns are subject to a 25% restocking and handling fee (25% of the gross value exc. P&P – at the prevailing price at time of purchase). The customer must pay any and all carriage charges. No returns of discontinued products, unless within 14 days of purchase. This policy does not affect your statutory rights and does not refer to faulty goods.