



LP0182

FITTING INSTRUCTIONS FOR LP0182BK LICENCE PLATE BRACKET
KAWASAKI NINJA H2 2015-

Page | 1



THIS KIT CONTAINS THE ITEMS PICTURED AND LABELLED BELOW.
DO NOT PROCEED UNTIL YOU ARE SURE ALL PARTS ARE PRESENT.

Please note that the way the kit is packed does not necessarily represent the way of mounting to the bike

THE PARTS SHOWN MAY BE REPRESENTATIVE ONLY (FOR CLARITY OF INSTRUCTIONS ONLY)

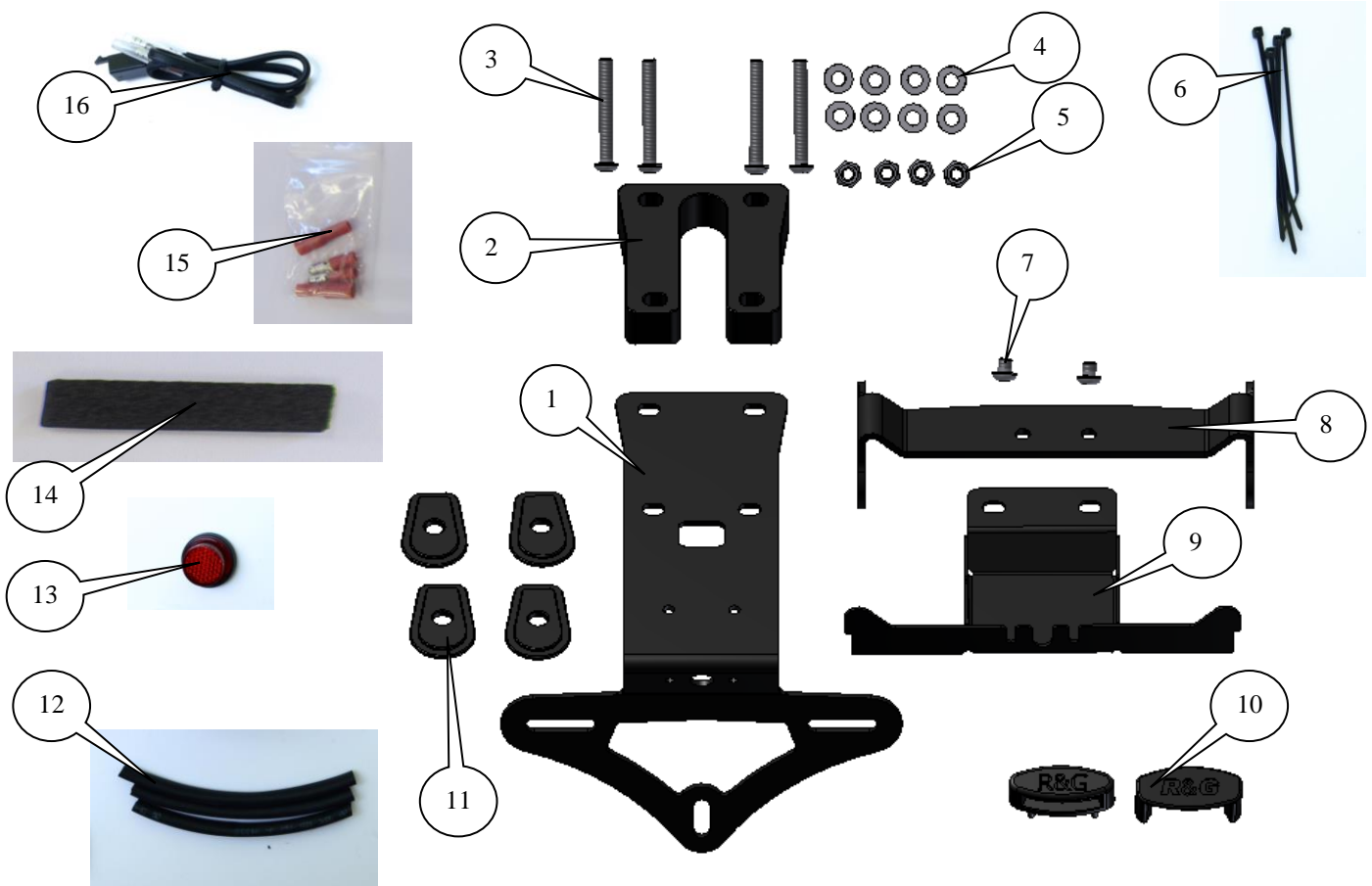

R&G Racing

Unit 1, Shelley's Lane, East Worldham, Alton, Hampshire, GU34 3AQ

Tel: +44 (0)1420 89007 Fax: +44 (0)1420 87301 www.rg-racing.com Email: info@rg-racing.com



LP0182

LEGEND

ITEM 1 = MAIN LICENCE PLATE MOUNTING BRACKET (TB0182BK-PART 1) (x1).

ITEM 2 = SHAPED MOUNTING SPACER (S0879) (x1).

Page | 2 ITEM 3 = M6x45mm BUTTON HEAD BOLTS (x4).

ITEM 4 = M6 WASHERS (x8).

ITEM 5 = M6 NYLOC NUTS (x4).

ITEM 6 = SMALL CABLE TIES (x4).

ITEM 7 = M6x6mm BUTTON HEAD BOLTS (x2).

ITEM 8 = INDICATOR MOUNTING BRACKET (TB0182BK-PART 2) (x1).

ITEM 9 = COVER/CABLE-TIDY (TB0182BK-PART 3) (x1).

ITEM 10 = LICENCE PLATE ILLUMINATOR ASSEMBLY (LA0002) (x1).

ITEM 11 = INDICATOR ADAPTORS (I0026) (x4).

ITEM 12 = 150mm LENGTHS OF HEAT SHRINK (x3).

ITEM 13 = REFLECTOR (REFL 1) (x1).

ITEM 14 = 100mm LENGTH SELF-ADHESIVE NEOPRENE FOAM (x2).

ITEM 15 = INDICATOR CONNECTORS (CON0004) (x2).

ITEM 16 = LICENCE PLATE ILLUMINATOR CONNECTOR (CON0007) (x1).

ITEM 17 = SELF ADHESIVE CABLE CLIPS (x2) (NOT SHOWN).

Please note that in cases where kits are packed with rubber washers holding the components onto the bolt – *the rubber washers should be thrown away!*

TOOLS REQUIRED

- Set of Metric Allen keys to include 3, 4 and 5mm A/F.
 - 10mm Socket and wrench.
 - Philips driver.
 - Electrical pliers/crimps.
 - Small amount of super glue.

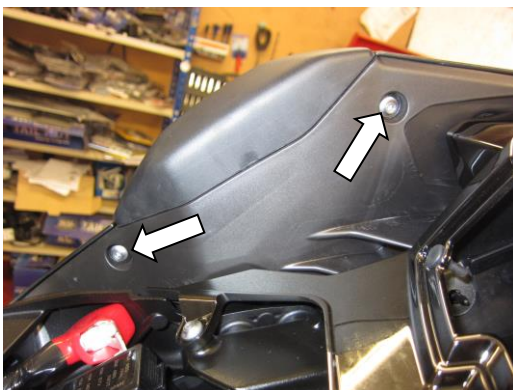

PICTURE 1



PICTURE 2



LP0182

Page | 3



PICTURE 3

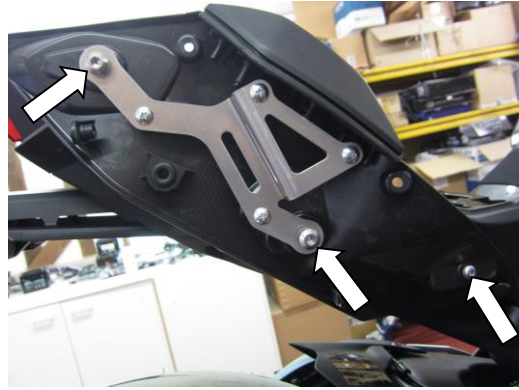

PICTURE 4



PICTURE 5



PICTURE 6



PICTURE 7



PICTURE 8



LP0182

Page | 4

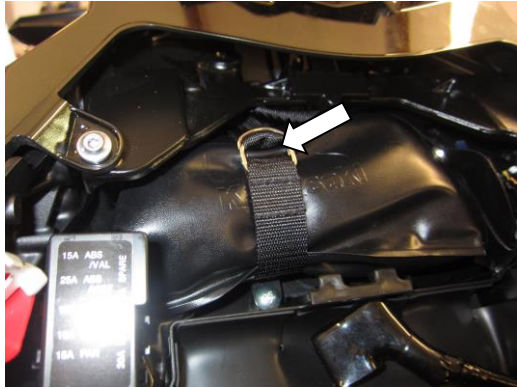

PICTURE 9

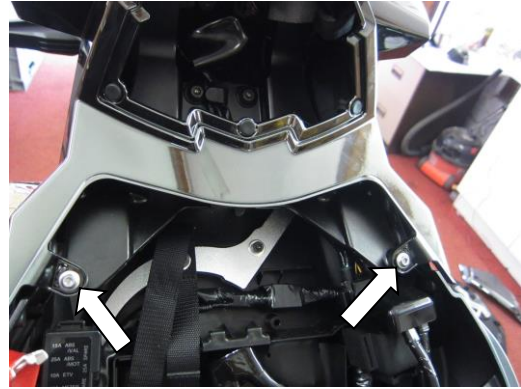

PICTURE 10

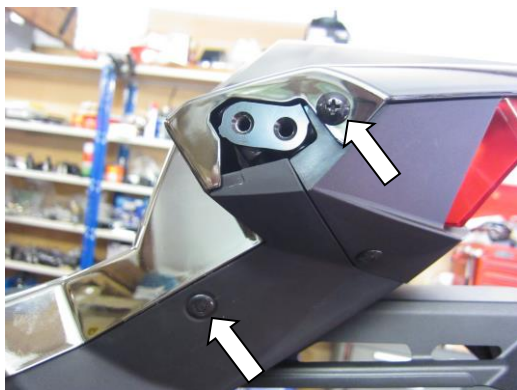

PICTURE 11

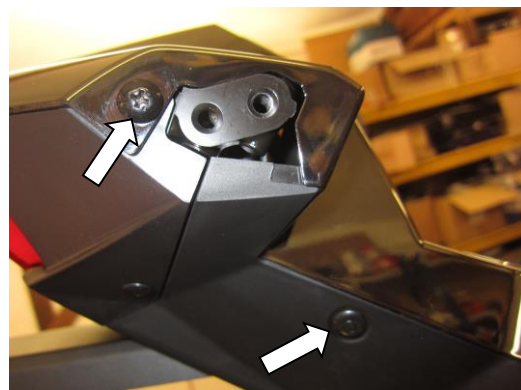

PICTURE 12



PICTURE 13



PICTURE 14



LP0182

Page | 5

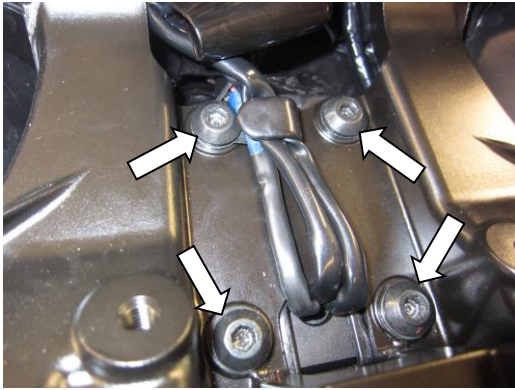

PICTURE 15

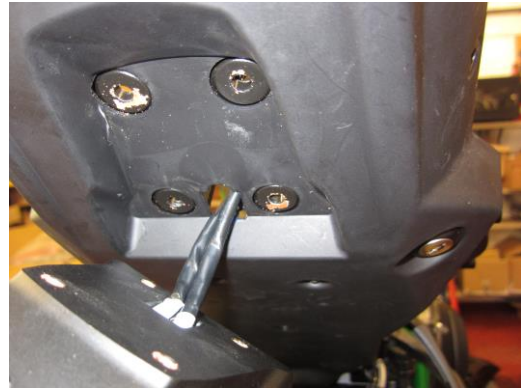

PICTURE 16

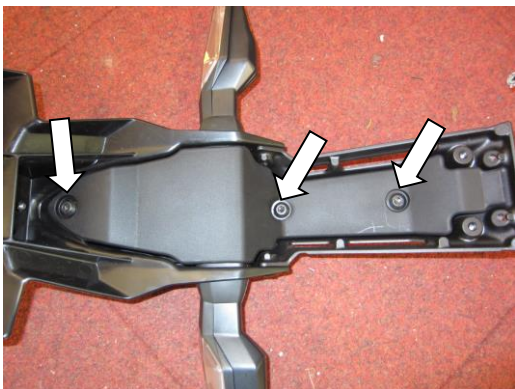

PICTURE 17



PICTURE 18

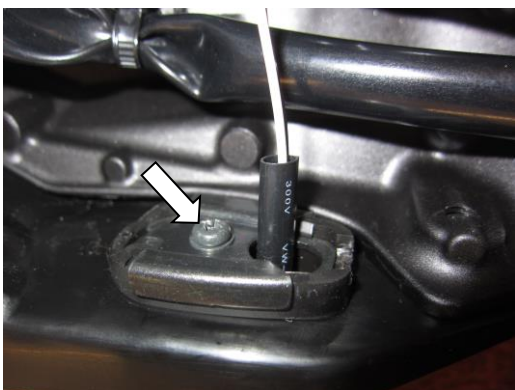

PICTURE 19



PICTURE 20



LP0182

Page | 6



PICTURE 21



PICTURE 22



PICTURE 23



PICTURE 24



PICTURE 25



PICTURE 26



LP0182

Page | 7



PICTURE 27



PICTURE 28

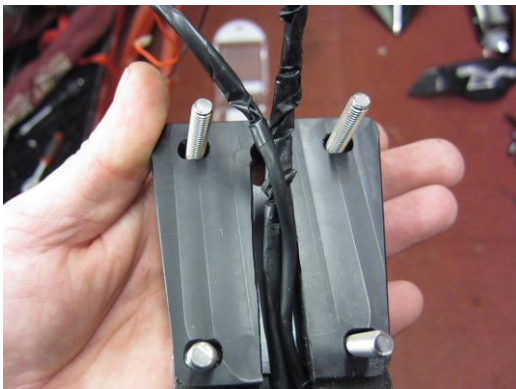

PICTURE 29

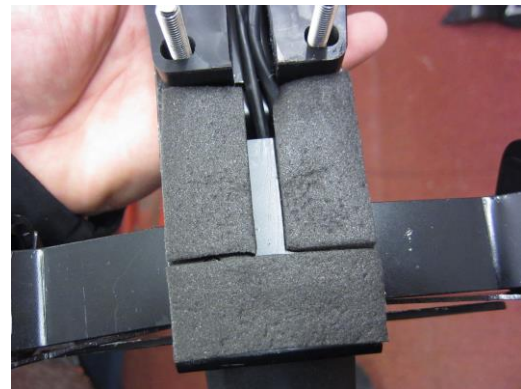

PICTURE 30

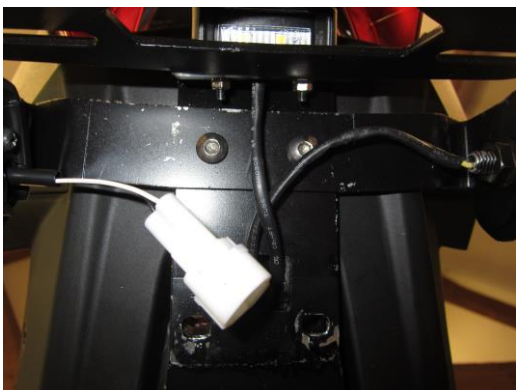

PICTURE 31



PICTURE 32



LP0182

Page | 8

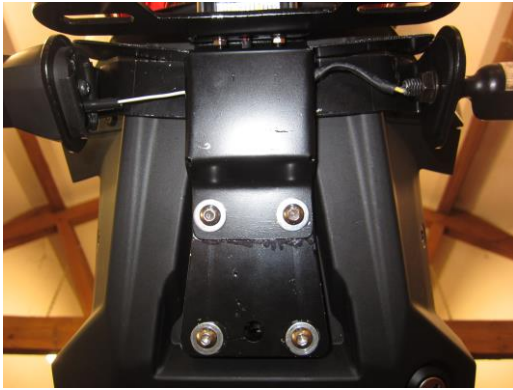

PICTURE 33



PICTURE 34

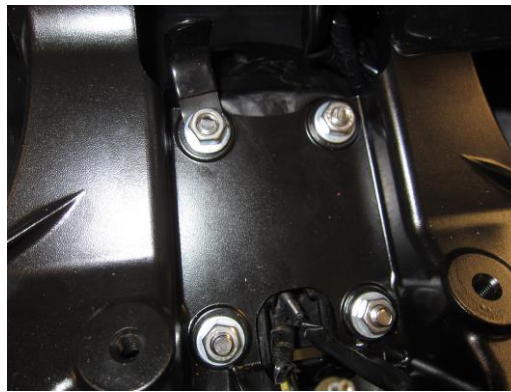

PICTURE 35

FITTING INSTRUCTIONS

- Remove the rider and pillion seat.
- Remove the four bolts arrowed in pictures 1, 2 and 3 and remove the right hand side outer panel.
- Remove the three bolts arrowed in picture 4 and remove the right hand side inner mounting panel.
- Remove the four bolts arrowed in pictures 5, 6 and 7 and remove the left hand side outer panel.
- Remove the three bolts arrowed in picture 8 and remove the left hand side inner mounting panel.
- Undo the tool kit clasp and remove the tool kit as shown in picture 9.
- With both side pods removed undo and remove the 2 bolts arrowed in picture 10.
- Remove the two bolts **and push rivets** arrowed in pictures 11 and 12 and remove the rear seat cowl.
- Disconnect the three wiring plug sockets shown in pictures 13 and 14.
- Unclip the wiring clamp and remove the four bolts arrowed in picture 15 whilst supporting the original licence plate bracket from underneath.

R&G Racing

Unit 1, Shelley's Lane, East Worldham, Alton, Hampshire, GU34 3AQ

Tel: +44 (0)1420 89007 Fax: +44 (0)1420 87301 www.rg-racing.com Email: info@rg-racing.com



LP0182

Page | 9

- Gently lower the licence plate bracket while feeding the wiring through the under-tray as shown in picture 16.
- With the licence plate bracket removed undo and remove the three bolts arrowed in picture 17, remove the cable cover to allow access to the indicators and wiring plug sockets.
- Disconnect the two plug sockets show in picture 18 (it is a good idea to mark which one comes from which side for reassembly later).

If reusing the original indicators

- Remove the screw arrowed in picture 19 and then the clamp plate.
- Remove the spreader plate as shown in picture 20, and then squeeze the rubber indicator stem to allow the indicator to be removed.
- Repeat the above to remove the other indicator.
- Fit the indicators to the indicator mounting bracket (item 8) as shown in pictures 21, 22, 23 and 24 in the same manner as they were mounted originally (ensure they are fitted on the correct sides).

If using Mini indicators

- If using mini's fit the indicators of choice to the indicator mounting bracket (item 8) (R&G mini indicator product code RG370 for bulb type and RG371 for LED type or RG372 for Aero Style led type) using the four indicator adaptors (item 11) (please use the provided heat shrink (item 12) to protect the wiring) as shown in pictures 25 and 26.
- Fit the new licence plate illuminator (item 10) to the new licence plate bracket (item 1) as shown in pictures 27 and 28 (please use the provided heat shrink (item 12) to protect the wiring).
- **PLEASE NOTE YOU WILL NEED TO GLUE THE LIGHT SHROUD TO THE LED LICENCE PLATE ILLUMINATOR USING SUPER GLUE.**
- Place the shaped mounting spacer (item 2) onto the licence plate mounting bracket (item 1) as shown in picture 29, use the bolts to align correctly.
- Cut and stick the self-adhesive foam (item 14) to the upper surface of the licence plate mounting bracket (item 1) as shown in picture 30.
- If using indicators fit the indicator mounting bracket (item 8) to the licence plate mounting bracket (item 1) using the two smaller M6 button head bolts (item 7) as shown in picture 31 and below.



R&G Racing

Unit 1, Shelley's Lane, East Worldham, Alton, Hampshire, GU34 3AQ
Tel: +44 (0)1420 89007 Fax: +44 (0)1420 87301 www.rg-racing.com Email: info@rg-racing.com



LP0182

- Feed all the wires through the square hole in item 1 as shown in pictures 29 and 30.
- Fit the cover/cable-tidy (item 9) into position ensure the wires are not trapped or stretched as shown in picture 33.
- Place two of the longer M6 button head bolts (item 3) with washers (item 4) through the licence plate bracket and shaped mounting spacer as shown below.

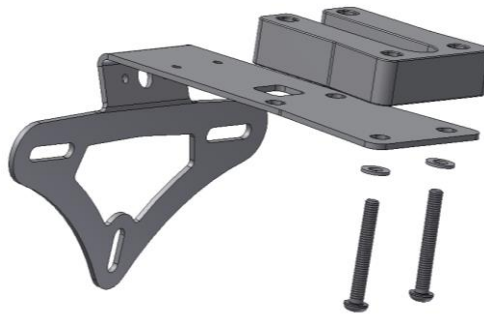

- Offer this assembly into position as shown in picture 34 while feeding the wires through the under-tray.
- Using two of the M6 nyloc nuts (item 5) with washers (item 4) secure the assembly in position (do not fully tighten the nuts at this stage).
- Position the two remaining M6 button head bolts (item 3) with the remaining M6 washers (item 4) through the cover/cable-tidy, through the main bracket as shown below.



- Using the remaining nuts (item 5) and washers (item 4) secure the assembly into position (please replace the wiring clamp as original) as shown in picture 35.
- Tighten all the nuts ensuring no parts of the assembly come into contact with any of the original body work.
- Connect the licence plate illuminator using the supplied wiring connector (item 16) to the original wiring plug socket.
- If using the original indicators use the original wiring harness (from the original licence plate bracket) to connect the indicators to the original wiring plug socket. It is a good idea to check the operation of the licence plate illuminator and indicators at this stage (if the licence plate illuminator fails to light please swap the bullet connectors over).

R&G Racing

Unit 1, Shelley's Lane, East Worldham, Alton, Hampshire, GU34 3AQ

Tel: +44 (0)1420 89007 Fax: +44 (0)1420 87301 www.rg-racing.com Email: info@rg-racing.com



LP0182

- If fitting the R&G Mini Indicators, the OEM indicator wiring will need to be “cut and shut” in order to re-use the connectors to connect the R&G Mini Indicators to the wiring loom. This is done by cutting the connectors off the OEM indicators, before fitting the bullet connectors (item 15) to the exposed wiring and connecting to the R&G indicators. Plug it into the loom to check at this stage (if illumination fails, swap the bullet connections around). (Please use the heat-shrink (item 12) to protect the new indicator wires). It is a good idea at this point to turn the ignition on and check for the correct operation of all lights.
- Refit the rear seat cowl as original.
- Refit the two inner mounting panels as original.
- Refit the two outer panels as original
- Use the cable ties to neaten and tidy the wiring
- Re-fit the licence plate (it may require drilling).
- **IMPORTANT: IF FITTING A FULL-SIZE LICENCE PLATE AND PLACING IT FAR DOWN ON THE LICENCE PLATE HANGER, THERE IS A SMALL CHANCE OF THE LICENCE PLATE HITTING THE BACK WHEEL UNDER HEAVY LOAD AND OVER LARGE BUMPS IN THE ROAD. IT IS YOUR RESPONSIBILITY TO CHECK FOR THIS POSSIBILITY AND TAKE AVOIDING ACTION. FAILURE TO CHECK THIS COULD RESULT IN SERIOUS INJURY OR DAMAGE.**
- Refit both seats.
- Depending on local laws, attach enclosed red reflector (item 13) in an appropriate location.
- **Please test the indicators, rear light and licence plate illuminator before riding.**

Digital copies of these instructions are available to download from www.rg-racing.com

GENERAL TORQUE SETTINGS

M4 BOLT = 8Nm
M5 BOLT = 12Nm
M6 BOLT = 15Nm
M8 BOLT = 20Nm
M10 BOLT = 40Nm

ISSUE 1 22/05/2015 (NSY)

CONSUMER NOTICE

The catalogue description and any exhibition of samples are only broad indications of the Products and R&G may make design changes which do not diminish their performance or visual appeal and supplying them in such state shall conform to the order. The Buyer acknowledges no representation or warranty (other than as to title) has been given or will apply to the Products other than those in R&G's order or confirmation and the Buyer confirms it has chosen the Products as being of merchantable quality and suitable for its particular purposes. Where R&G fits the Products or undertakes other services it shall exercise reasonable skill and care and rectify any fault free of charge unless the workmanship has been disturbed. The Buyer is responsible for ensuring that the warranty on the motorcycle is not affected by the fitting of the Products. On return of any defective Products R&G shall at its option either supply a replacement or refund the purchase money but shall not be liable if the Products have been modified or used or maintained otherwise than in accordance with R&G's or manufacturer's instructions and good engineering practice or if the defect arises from accident or neglect. Other than identified above and subject to R&G not limiting its liability for causing death and personal injury, it shall not be liable for indirect or consequential loss and otherwise its liability shall be limited to the amounts paid by the Buyer for the Products or the fitting or service concerned. These terms do not affect the Buyer's statutory rights.

R&G RACING RETURNS POLICY (NON-FAULTY GOODS)

Returns must be pre-authorized (if not pre-authorized the return will be rejected). Goods may only be returned direct to us if they were purchased direct from us (customer must prove if necessary). Otherwise to be returned to original vendor. Goods must be in re-sellable condition, in the opinion of R&G Racing. All returns are subject to a 25% restocking and handling fee (25% of the gross value exc. P&P – at the prevailing price at time of purchase). The customer must pay any and all carriage charges. No returns of discontinued products, unless within 14 days of purchase. This policy does not affect your statutory rights and does not refer to faulty goods.

R&G Racing

Unit 1, Shelley's Lane, East Worldham, Alton, Hampshire, GU34 3AQ

Tel: +44 (0)1420 89007 Fax: +44 (0)1420 87301 www.rg-racing.com Email: info@rg-racing.com



LP0182

**INSTRUCTIONS DE MONTAGE POUR LP0182BK SUPPORT DE PLAQUE
KAWASAKI NINJA H2 2015-**

Page | 12



Assurez vous que toutes les pièces soient présentes avant de procéder au montage.

La façon dont le kit est emballé ne correspond pas forcément à la façon de monter les pièces sur la moto.

LES PIÈCES PRESENTÉES PEUVENT N'ÊTRE QUE REPRESENTATIVES, AFIN DE FACILITER ET CLARIFIER LES INSTRUCTIONS DE MONTAGE.

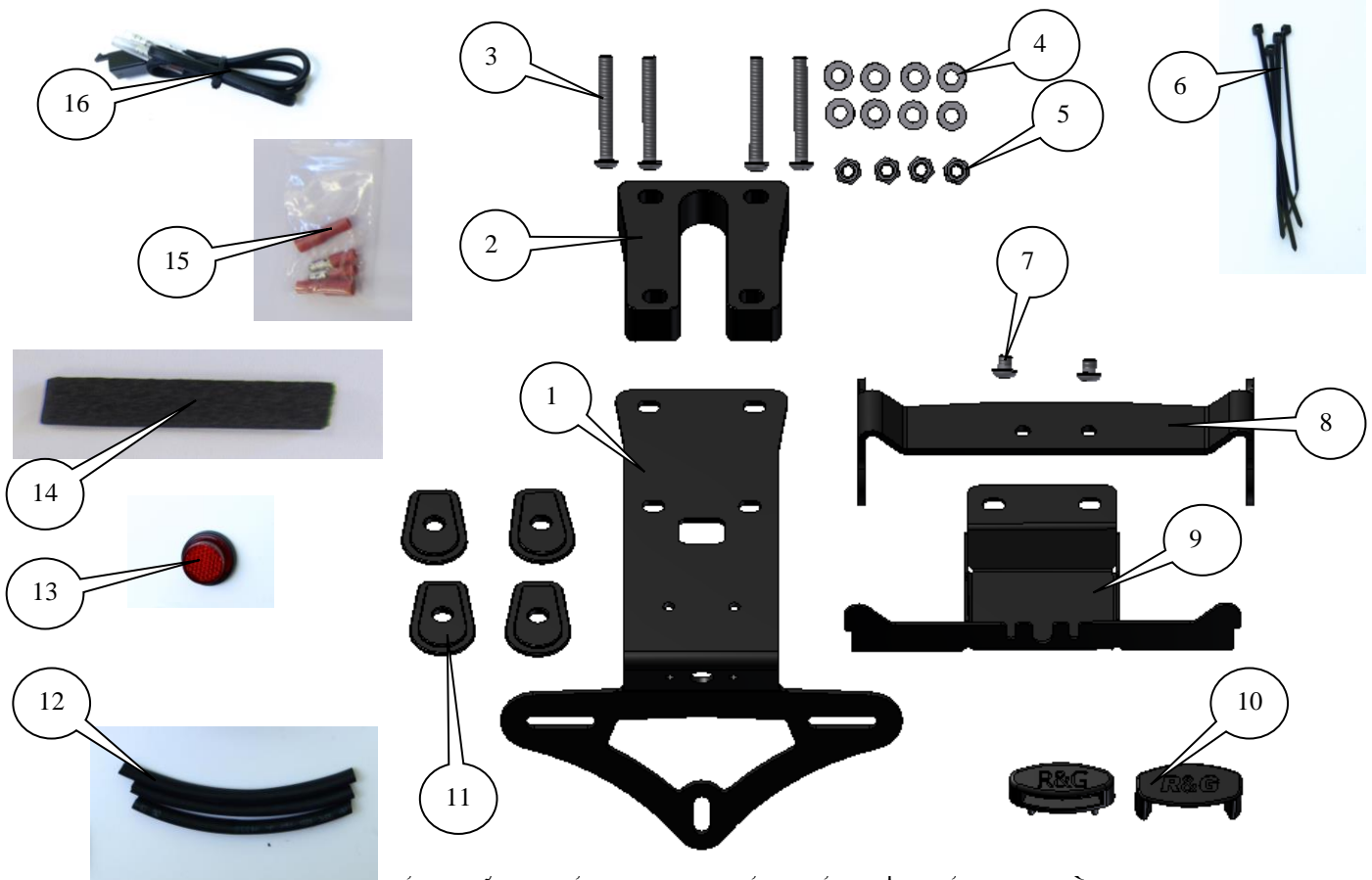



LP0182

Page | 13

LEGENDE

- ARTICLE 1 = SUPPORT DE PLAQUE PRINCIPAL (TB0182BK-PARTIE 1) (x1).
ARTICLE 2 = ENTRETOISE (S0879) (x1).
ARTICLE 3 = M6x45mm BOULONS (x4).
ARTICLE 4 = M6 RONDELLES (x8).
ARTICLE 5 = M6 ÉCROUS (x4).
ARTICLE 6 = PETITS COLLIERS (x4).
ARTICLE 7 = M6x6mm BOULONS (x2).
ARTICLE 8 = SUPPORT DE FIXATION CLIGNOTANT (TB0182BK-PARTIE 2) (x1).
ARTICLE 9 = CACHE CABLE (TB0182BK-PARTIE 3) (x1).
ARTICLE 10 = ASSEMBLAGE FEU DE PLAQUE (LA0002) (x1).
ARTICLE 11 = ADAPTATEURS CLIGNOTANTS (I0026) (x4).
ARTICLE 12 = 150mm LONGUEURS THERMO RETRACTABLES (x3).
ARTICLE 13 = REFLECTEUR (REFL 1) (x1).
ARTICLE 14 = 100mm LONGUEURS DE MOUSSE NEOPRENE AUTOCOLLANTES (x2).
ARTICLE 15 = CONNECTEURS DE CLIGNOTANT (CON0004) (x2).
ARTICLE 16 = CONNECTEUR DE FEU DE PLAQUE (CON0007) (x1).
ARTICLE 17 = SERRE CABLES AUTOCOLLANTS (x2) (NON INDIQUE).

Notez que si les kits sont emballés avec des rondelles en caoutchouc servant à tenir les composants, *ces rondelles doivent être jetées.*

OUTILS REQUIS

- Jeu de clés Allen 3, 4 & 5mm
 - Clé et douille 10mm.
- Tournevis cruciforme.
 - Pincés électriques.
- Un peu de superglue.

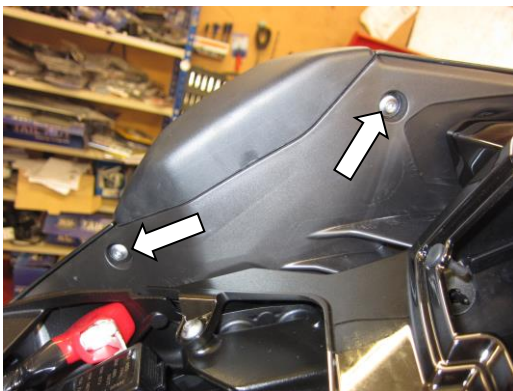

PHOTO 1



PHOTO 2

R&G Racing
Unit 1, Shelley's Lane, East Worldham, Alton, Hampshire, GU34 3AQ
Tel: +44 (0)1420 89007 Fax: +44 (0)1420 87301 www.rg-racing.com Email: info@rg-racing.com



LP0182

Page | 14



PHOTO 3

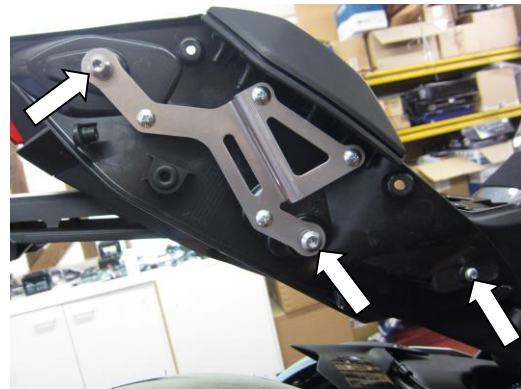

PHOTO 4



PHOTO 5



PHOTO 6



PHOTO 7



PHOTO 8

R&G Racing
Unit 1, Shelley's Lane, East Worldham, Alton, Hampshire, GU34 3AQ
Tel: +44 (0)1420 89007 Fax: +44 (0)1420 87301 www.rg-racing.com Email: info@rg-racing.com



LP0182

Page | 15



PHOTO 9

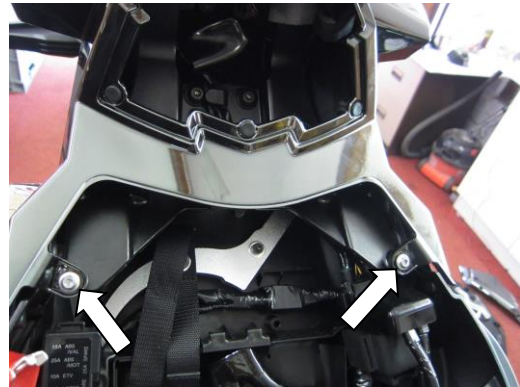

PHOTO 10

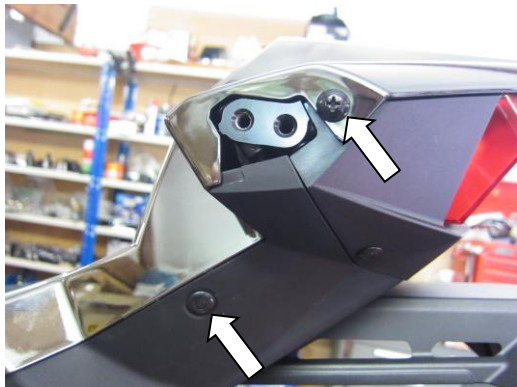

PHOTO 11

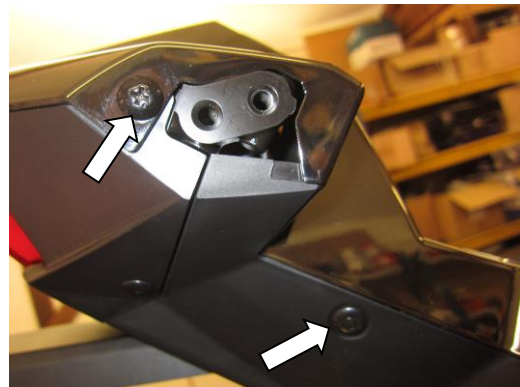

PHOTO 12



PHOTO 13



PHOTO 14



LP0182

Page | 16

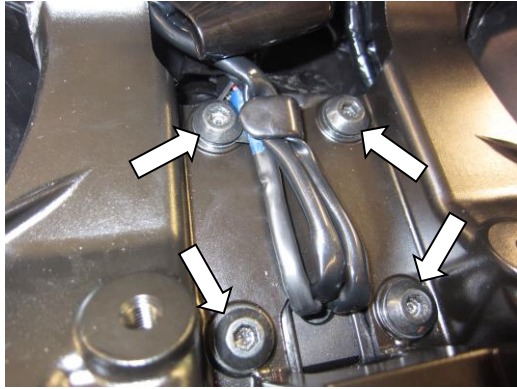

PHOTO 15

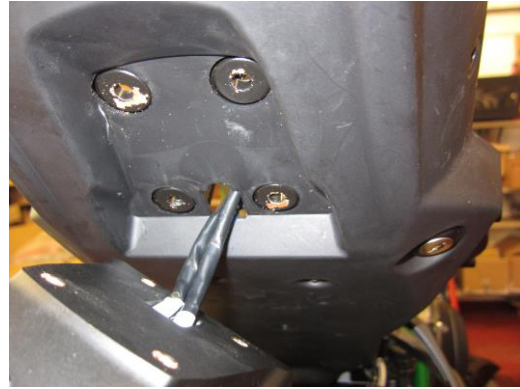

PHOTO 16

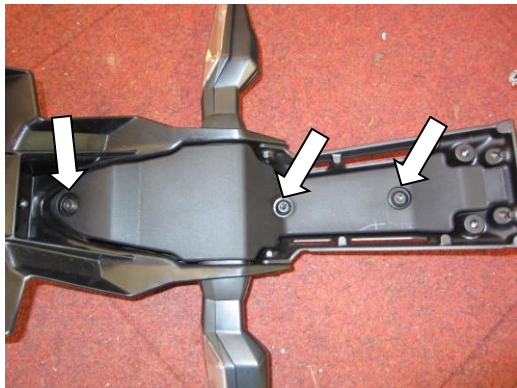

PHOTO 17



PHOTO 18

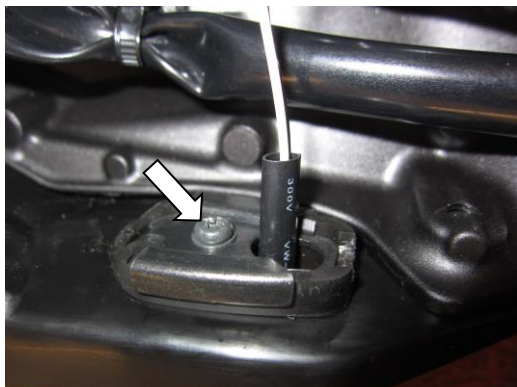

PHOTO 19



PHOTO 20



LP0182

Page | 17



PHOTO 21



PHOTO 22



PHOTO 23



PHOTO 24



PHOTO 25



PHOTO 26

R&G Racing
Unit 1, Shelley's Lane, East Worldham, Alton, Hampshire, GU34 3AQ
Tel: +44 (0)1420 89007 Fax: +44 (0)1420 87301 www.rg-racing.com Email: info@rg-racing.com



LP0182

Page | 18



PHOTO 27



PHOTO 28

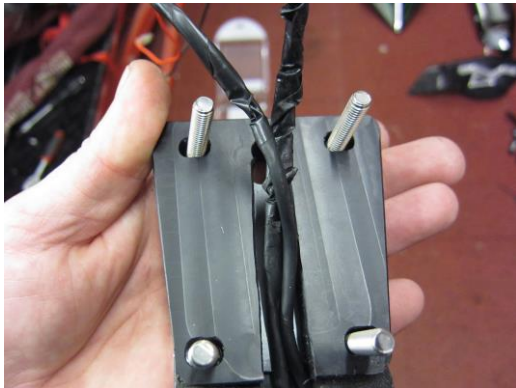

PHOTO 29

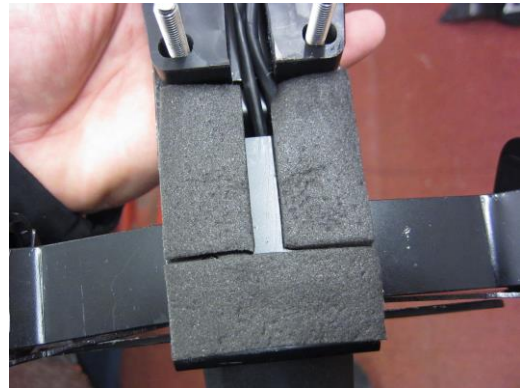
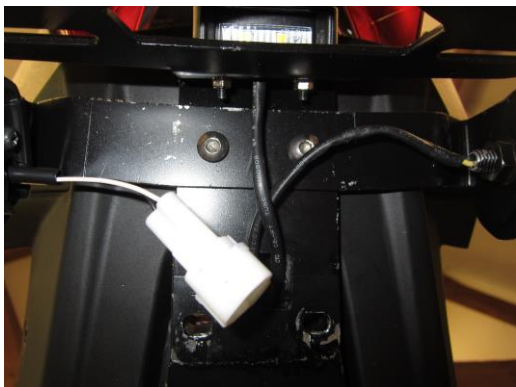

PHOTO 30





LP0182

PHOTO 31

PHOTO 32

Page | 19



PHOTO 33



PHOTO 34



PHOTO 35

INSTRUCTIONS DE MONTAGE :

- Enlever le siège pilote et passager.
- Enlever les 4 boulons indiqués sur les photos 1, 2 et 3 puis enlever le cache extérieur coté droit.
- Enlever les 3 boulons indiqués sur la photo 4 puis enlever le cache de fixation interne du coté droit.
- Enlever les 4 boulons indiqués sur les photos 5, 6 et 7 puis enlever le cache externe du coté gauche.
- Enlever les 3 boulons indiqués sur la photo 8 et enlever le cache de fixation intérieur du coté gauche.
- Défaire le kit outil fermoir et enlever le kit outil, voir photo 9.
- Une fois les sacs deux cotés enlevés, enlever les 2 boulons indiqués sur la photo 10.
- Enlever les 2 boulons et pousser rivets indiqués sur les photos 11 et 12 puis enlever le capot de siège arrière.
- Déconnecter les 3 prises de fils, voir photos 13 et 14.
- Défaire l'agrafe de fils puis enlever les 4 boulons indiqués sur la photo 15 tout en supportant le support de plaque d'origine par le dessous.

R&G Racing

Unit 1, Shelley's Lane, East Worldham, Alton, Hampshire, GU34 3AQ

Tel: +44 (0)1420 89007 Fax: +44 (0)1420 87301 www.rg-racing.com Email: info@rg-racing.com



LP0182

Page | 20

- Abaisser le support de plaque tout en passant les fils dans le passage de roue, voir photo 16.
- Une fois le support de plaque enlevé, desserrer puis enlever les 3 boulons indiqués sur la photo 17. Enlever le cache câble pour permettre l'accès aux clignotants et les prises de fils.
- Déconnecter les 2 prises indiquées sur la photo 18 (Il est bon de les marquer pour s'y retrouver plus facilement lors du remontage).

Si vous utilisez les clignotants d'origine

- Enlever la vis indiquée sur la photo 19 puis la plaque d'attache.
- Enlever la plaque d'écartement comme indiqué sur la photo 20, puis presser le caoutchouc du clignotant pour permettre d'enlever le clignotant.
- Répéter l'action du dessus pour enlever l'autre clignotant.
- Monter les clignotants sur le support de fixation (article 8), voir photos 21, 22, 23 et 24 de la même façon qu'ils avaient été montés à l'origine (Veiller à ce qu'ils soient montés du bon coté).

Si vous utilisez les mini clignotants

- Si vous utilisez les mini clignotants, montez ceux de votre choix au support de fixation de votre choix au support de fixation clignotant (article 8) (Les minis clignotants R&G mini code produit RG370 pour type ampoule et RG371 pour type LED ou RG372 pour type latéral) à l'aide des 4 adaptateurs de clignotants (article 11) (utiliser la gaine thermo rétractable fournie (article 12) pour protéger les fils) voir photos 25 et 26.
- Monter le nouveau feu de plaque (article 10) au nouveau support de plaque (article 1) comme sur les photos 27 et 28 (utiliser le manchon thermo rétractable fourni (article 12) pour protéger les fils).
- **VOUS DEVREZ COLLER LE LINCEUL DE FEU AU FEU DE PLAQUE LED A L'AIDE DE LA SUPERGLUE.**
- Placer l'entretoise (article 2) sur le support de fixation de la plaque (article 1) voir photo 29, utiliser les boulons pour aligner correctement.
- Couper et coller la mousse autocollante (article 14) sur la surface supérieure du support de fixation de plaque (article 1), voir photo 30.
- Si vous utilisez les clignotants classiques, monter le support de fixation de clignotant (article 8) sur le support de fixation de la plaque (article 1) à l'aides des 2 boulons M6 les plus petits (article 7), voir photo 31 et en dessous.



R&G Racing

Unit 1, Shelley's Lane, East Worldham, Alton, Hampshire, GU34 3AQ

Tel: +44 (0)1420 89007 Fax: +44 (0)1420 87301 www.rg-racing.com Email: info@rg-racing.com



LP0182

Page | 21

- Passer tous les fils dans le trou carré (article 1), voir photos 29 et 30.
- Installer le cache/serre câble (article 9) en position, en veillant à ce que les fils ne soient pas pincés, voir photo 33.
- Placer 2 des boulons M6 (article 3) avec rondelles (article 4) dans le support de plaque puis l'entretoise de fixation, comme indiqué ci-dessous.

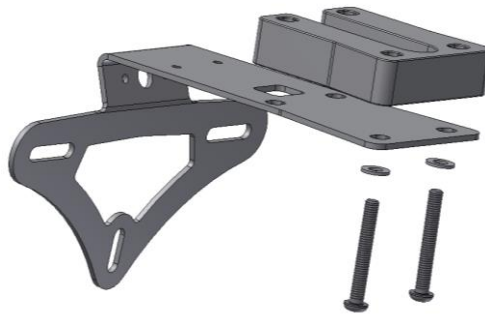

- Monter l'ensemble en position, voir photo 34 tout en passant les fils dans le passage de roue.
- Utiliser 2 des écrous M6 (article 5) avec rondelles (article 4) pour fixer l'ensemble en position (Ne pas bloquer les écrous à ce stade).
- Positionner les 2 boulons M6 restants (article 3) avec les rondelles M6 restantes (article 4) dans le cache/serre câble, à travers le support principal, voir ci-dessous.



- En utilisant les écrous restants (article 5) et les rondelles (article 4), fixer l'ensemble en position (remettre l'agrafe de fils comme à l'origine), voir photo 35.
- Serrer tous les écrous en veillant à ce qu'aucune partie ne puisse entrer en contact avec le carénage.
- Connecter le feu de plaque en utilisant les connecteurs de fils fournis (article 16) à la prise d'origine.
- Si vous utilisez le harnais des clignotants d'origine (du support de plaque d'origine) pour connecter les clignotants à la prise d'origine. Il est conseillé de vérifier qu'à ce stade, tous les feux fonctionnent correctement (si le feu de plaque échoue, permutez les connecteurs).

R&G Racing

Unit 1, Shelley's Lane, East Worldham, Alton, Hampshire, GU34 3AQ

Tel: +44 (0)1420 89007 Fax: +44 (0)1420 87301 www.rg-racing.com Email: info@rg-racing.com



LP0182

Page | 22

- Si vous monter les minis clignotants R&G, les fils de clignotants d'origine devront être « coupés puis fermés » pour réutiliser les connecteurs afin de connecter les mini clignotants R&G au linéol de feu. Cela s'effectue en coupant les connecteurs des clignotants d'origine, avant de monter les connecteurs (article 15) sur les fils puis connecter les clignotants R&G. Branchez le dans le métier à tisser pour vérifier à ce stade (si l'éclairage échoue, permutez les connexions). (Utilisez svp le manchon thermo rétractable (article 12) pour protéger les fils de nouveaux clignotants). Il est conseillé de mettre le contact à ce stade, pour vérifier le fonctionnement des feux.
- Remettre le capot arrière comme à l'origine.
- Remettre les 2 carénages internes comme à l'origine
- Remettre les 2 carénages externes comme à l'origine
- Utiliser les colliers pour organiser les fils
- Remettre la plaque (peut nécessiter un perçage).
- **IMPORTANT: Si vous installez une grosse plaque, il y a un risque que la plaque entre en contact avec la roue arrière en cas de choc sur la route (bosse, grosse charge etc...). Il est de votre responsabilité de vérifier que cela ne puisse pas se produire. Ne pas effectuer ces vérifications peut entraîner des dommages ainsi que des blessures graves pour le pilote.**
- Remettre les 2 sièges.
- Selon la loi locale, monter les réflecteurs (article 13) aux emplacements appropriés.
- **Revérifiez que les clignotants et les feux de plaque fonctionnent bien avant de prendre la route.**

Ces instructions de montage sont disponibles sur www.rg-racing.com

COUPLES DE SERRAGE :

M4 BOULON = 8Nm
M5 BOULON = 12Nm
M6 BOULON = 15Nm
M8 BOULON = 20Nm
M10 BOULON = 40Nm

ISSUE 1 22/05/2015 (NSY)

CONSUMER NOTICE

The catalogue description and any exhibition of samples are only broad indications of the Products and R&G may make design changes which do not diminish their performance or visual appeal and supplying them in such state shall conform to the order. The Buyer acknowledges no representation or warranty (other than as to title) has been given or will apply to the Products other than those in R&G's order or confirmation and the Buyer confirms it has chosen the Products as being of merchantable quality and suitable for its particular purposes. Where R&G fits the Products or undertakes other services it shall exercise reasonable skill and care and rectify any fault free of charge unless the workmanship has been disturbed. The Buyer is responsible for ensuring that the warranty on the motorcycle is not affected by the fitting of the Products. On return of any defective Products R&G shall at its option either supply a replacement or refund the purchase money but shall not be liable if the Products have been modified or used or maintained otherwise than in accordance with R&G's or manufacturer's instructions and good engineering practice or if the defect arises from accident or neglect. Other than identified above and subject to R&G not limiting its liability for causing death and personal injury, it shall not be liable for indirect or consequential loss and otherwise its liability shall be limited to the amounts paid by the Buyer for the Products or the fitting or service concerned. These terms do not affect the Buyer's statutory rights.

R&G RACING RETURNS POLICY (NON-FAULTY GOODS)

Returns must be pre-authorized (if not pre-authorized the return will be rejected). Goods may only be returned direct to us if they were purchased direct from us (customer must prove if necessary). Otherwise to be returned to original vendor. Goods must be in re-sellable condition, in the opinion of R&G Racing. All returns are subject to a 25% restocking and handling fee (25% of the gross value exc. P&P – at the prevailing price at time of purchase). The customer must pay any and all carriage charges. No returns of discontinued products, unless within 14 days of purchase. This policy does not affect your statutory rights and does not refer to faulty goods.

R&G Racing

Unit 1, Shelley's Lane, East Worldham, Alton, Hampshire, GU34 3AQ

Tel: +44 (0)1420 89007 Fax: +44 (0)1420 87301 www.rg-racing.com Email: info@rg-racing.com